

**studies and documents
on
the cultural heritage**

6

**Emergency
measures and
damage
assessment
after an
earthquake**

unesco

Emergency measures and damage assessment after an earthquake

Pierre Pichard

CLT/84/WS/14

Preface

Unesco has always been concerned with the protection of mankind's cultural heritage against the many natural and man-made dangers which beset it. Among the natural factors of deterioration are those which cause rapid and dramatic destruction: disasters, the origin of which may be telluric (earthquakes, tsunamis, landslides, volcanic eruptions), meteorological (cyclones, tornados) or hydrological (floods, tidal waves, avalanches, etc.). Apart from their tragic toll in human life and suffering all such disasters unleash blind forces which literally devastate man's cultural heritage.

These phenomena are still largely unpredictable (although research into the forecasting of earthquakes is making great advances). However, studies have shown that the damage to cultural property could be less extensive if the right measures were taken to reduce its vulnerability and to ensure emergency safeguard. Protection of the cultural heritage is rarely integrated into civil and military protection plans. So, when a disaster occurs, looting and unnecessary demolition may well follow. Few historic buildings have been strengthened to resist earthquakes for example, although the general engineering principles of earthquake-resistance are now well known.

The magnitude of the damage caused by all natural disasters is infinite. But it is earthquakes which demonstrate the greatest power of destruction and at the same time take the heaviest toll in human life. The beautiful old towns of Cuzco and Trujillo in Peru were seriously damaged by earthquakes in 1950 and 1971 respectively; the 1975 earthquake in Burma devastated Pagan, the ancient city of 2,000 Buddhist pagodas; Antigua Guatemala and Friuli (Italy) were rocked by earthquakes in 1976; the Algerian town of El-Asnam has been struck by earthquakes three times in 46 years - the last, in 1980, damaged archaeological sites in the surrounding region; the Republic of Montenegro was ravaged in 1979 by one of the most violent earthquakes to occur in the last few years; the Popayan earthquake of 1983 razed to the ground this historic town, jewel of Colombian colonial architecture. These are but a few examples of the terrible destructive power of earthquakes.

In almost all of these cases, Unesco has, in the aftermath of the disaster, helped to review its effects on the cultural heritage and to advise on restoration and safeguarding measures. Several major campaigns launched to mobilize international solidarity for the safeguarding of the cultural heritage had as their starting-point emergency action required in the wake of a natural catastrophe: the campaigns to save the historic city of Venice following the flooding and land subsidence, to preserve and present historic monuments and sites in Guatemala damaged by the 1976 earthquake, particularly in Antigua, Guatemala City and Chichicastenango, to safeguard the cultural heritage of Montenegro (Yugoslavia) where an earthquake devastated the historic parts of many old walled towns, and also museums and archives. Technical co-operation possibilities have been further extended by the adoption of the Convention concerning the protection of the world cultural and natural heritage under which assistance can be granted to States Parties for the safeguarding of cultural properties which have been identified as forming part of the 'world heritage'. Emergency assistance has, for instance, been made available for restoration work in Antigua Guatemala and at Kotor in Montenegro, both of which have been declared world heritage sites.

Emergency technical missions have also been carried out. Thus, a three-man team (including the author of the present document) visited the Region of Friuli after the 1976 earthquake to study its effects and, in consultation with the local authorities, to develop plans for the protection and restoration of the affected historical monuments and educational facilities. The Organization, once again using the services

of the author, also co-operated with the Government of Burma in taking stock of the extensive damage to the temples of Pagan and in working out restoration plans.

Unesco has also promoted international study and exchange of experience with a view to promoting professional practice in this field. Two high-level expert meetings were held in 1977 and 1979. The conclusions of the latter, a seminar-cum-workshop held in Guatemala and devoted mainly to problems in seismic areas of Latin America, were combined with the scientific and technical papers presented at the meeting and published in 1983 by the UNDP/Unesco Regional Project on Cultural Heritage at Lima as a booklet entitled La protección de monumentos históricos en áreas sísmicas.

It has also been found necessary to publish some technical information for the purpose of (i) alerting national and local conservation authorities to the earthquake threat and the possibility of a disaster affecting the cultural property in their charge; (ii) laying down simple preventive rules designed to minimize damage in the event of a disaster and to prepare for emergency action; and (iii) indicating the emergency measures that can be taken after an earthquake to protect the damaged heritage and to facilitate repair and preservation work later on.

This publication attempts to respond to the third need. Its author is Pierre Pichard, a French architect who has been working for a long time on programmes to restore and inventory historic monuments, chiefly in Asia. After the Pagan (Burma) earthquake in 1975 he took part in the initial meetings organized by Unesco and the International Council of Monuments and Sites (ICOMOS) on the protection of historic monuments in earthquake zones. He is at present co-ordinating the international project for protection of the cultural heritage of Burma. He is a member of the 'Earthquake' Committee of ICOMOS, and of the Ecole Française d'Extrême-Orient since 1979. His extensive experience in the field (Friuli, Montenegro and Burma) has brought home to the author the need to define a methodology for systematic assessment of the damage caused to historic monuments by earthquakes.

The author is responsible for the choice and the presentation of the facts contained in this book and for the opinions expressed therein, which are not necessarily those of Unesco and do not commit the Organization.

Definitions

The Service: the agency for the preservation of cultural property, for which this handbook is designed. It may consist of a mere few persons (the curator and watchman of a monument or museum) or be the local or regional agency of the National Service for the Preservation of Historic Monuments, which goes by different names in different countries: Office for the Superintendents of Cultural Property, Department of Archaeology, etc.

The critical period: the first few days after an earthquake (sometimes a week), during which all activities are completely disorganized, while the relief teams are just beginning to arrive and emergency measures have not yet brought the situation under control.

A monument: means, in the broad sense (an isolated monument, a group of monuments, an old town, an archaeological site, etc.), an item of immovable cultural property classified as a 'protected monument' in accordance with the country's laws, and consequently the responsibility of the Service, and listed in an inventory; it may be publicly or privately owned. The recommendations in this handbook also apply to buildings containing collections of movable cultural property: museums, libraries, archives, etc., especially if they are old buildings (in the case of new buildings, it is to be hoped that the seismic codes in force were applied in their construction).

INTRODUCTION

An earthquake strikes a town, its surroundings or perhaps a whole area. For the next few days there is an emergency. Communication problems at all levels - roads cut off, bridges destroyed, electricity and telephone lines down - complicate the organization of relief and rescue operations and the transport of persons and equipment. This is the critical period.

The protection of the population is obviously the first priority. In cases where an emergency plan has been worked out before the disaster, the protection services (civil and military authorities, voluntary organizations, local initiative) can be co-ordinated faster and more efficiently.

It is highly unusual for emergency plans, when they exist, to provide for protection of the cultural heritage. For these first few days all efforts and resources are mobilized for the rescue and survival of the victims and the restoration of essential activities. Consequently those responsible for preserving the cultural heritage cannot count on receiving any outside assistance during the critical period and must rely on their own resources for the initial protection of the property in their care. Later on, the damage suffered by this property will be included in the total inventory of the disaster, and measures of repair, restoration and preservation will form part of the programme for the reconstruction of the disaster area in accordance with the priorities assigned by the national or regional authorities.

The purpose of this small handbook is to assist those responsible for the preservation of the cultural heritage at the local level during the critical period and the ensuing weeks. Such matters as the restoration of damaged monuments, the preventive reinforcement of old buildings situated in an earthquake zone, or long-term activities generally are not dealt with here, although the measures recommended are designed to make it easier to prepare for such activities and to carry them out later on. It is hoped that this document will be made available on the spot, in curators' offices and in the local agencies of the Service in earthquake zones, and that the personnel concerned will be able to consult it as soon as possible, so as to be better prepared to act effectively if disaster strikes.

Obviously the Service should in theory be staffed commensurately with its needs, but this is not always the case in normal times. During the critical period the staff will always be insufficient, all the more so since some of them may be unavailable (direct victims of the disaster; family affected; homeless, evacuated, etc.). An immediate response then has to be made to an exceptional situation with reduced means.

The activities described in this handbook, in chronological order beginning at the moment of the disaster, are dangerous activities, for they involve approaching and entering shaken and fragile buildings: there is a constant danger of collapse. Even though this is not repeated on every page, the greatest caution is imperative. Above all, no one should enter a damaged monument unless it is absolutely necessary in order to carry out a specific task. If the task can be performed by one or two people, they should see to it that unneeded assistants or members of the public moved by idle curiosity stay outside.

The general guidance given in this handbook will be found applicable in most cases. Every earthquake is, of course, a special case, and there will be times when some of the measures recommended will be impracticable or serve no purpose. Again, it may happen that the sequence of activities is unsuited to the local situation, or that some of the operations described here as separate and consecutive can be carried

on simultaneously. Every Service wishing to apply a policy of prevention would do well to draw up, on the basis of the recommendations in this handbook, a plan of action and instructions adapted more specifically to local conditions.

There are, broadly speaking, three types of cases that differ sharply in the scope of the problems which the Service will be called upon to solve in the event of a disaster:

1. Damage concentrated in a few places. Either the earthquake affects only a limited area containing only a few protected monuments, or the Service is concerned with conserving only one or a few monuments or sites. This is the simplest situation.
2. Damage occurring at many points over a relatively wide area. This is the commonest situation for a regional service for the preservation of historic monuments to face when a major earthquake occurs. Activities are then complicated by difficulties of communication and movement.
3. Damage affecting, in the same buildings, the cultural heritage and a substantial part of the population. This happens, in particular, when old towns, or historic quarters of large towns, are hit. The efforts of the Service will have to follow, and be subordinated to, the priority operations to rescue and evacuate the inhabitants, and closer co-ordination - sometimes difficult to achieve - will be needed between the Service and the civil and/or military authorities. At another level a similar situation arises when victims (staff or visitors) are found in the ruins of protected monuments.

WARNING!

After an earthquake, all measures and all decisions must be taken with the possibility of aftershocks in mind. Many earthquakes, as we know, are followed by such aftershocks: that is to say, by new earthquakes which strike in much the same area, which are unpredictable in number, date and scale, and which are equally likely to occur a few minutes or several months after the first shock. These aftershocks may be less violent than the initial earthquake and still be highly dangerous because weakened buildings have lost their capacity to withstand them; but they may also be as severe as the first shock or even more violent.

Example: The earthquake of 6 May 1976, of magnitude M 6.5, severely damaged the region of Friuli in northern Italy. There were many aftershocks, the strongest of which occurred on 15 September 1976 - four months later - and led to the total collapse of many monuments and buildings that had been merely cracked by the first shock on 6 May.

For several months, therefore, an earthquake should be regarded as the beginning of a period of constant danger, perhaps with the worst yet to come.

1. First inspection

As soon as possible after an earthquake - the same day or the next day - the first task of the Service is to survey the extent of the damage. The aim is not to make a detailed assessment - that comes later - but only to obtain an initial picture of the situation in order to:

- (a) inform the local, regional and national authorities;
- (b) identify the most urgent needs and the first measures to be taken;
- (c) prepare for the next stage of operations.

Every monument for which the service is responsible should be quickly examined, inspected if possible and classified in one or more of the following categories:

- A. Monument totally destroyed
- B. Monument partly destroyed
- C. Monument damaged
- D. Guard needed
- E. Movable property to be evacuated
- F. Temporary covering needed
- G. Monument intact.

(a) Classification criteria

- A. Monument totally destroyed. Total collapse.
- B. Monument partly destroyed. Partial collapse: note the parts destroyed and classify the parts still standing in categories C-G.
- C. Monument damaged. Monument still standing, but with several components (wall or part of wall, vault, floor, roof, etc.) collapsed or cracked. Briefly indicate the most seriously damaged components.
- D. Guard needed. Identify cases in which the monument should be given immediate protection from looting. This applies primarily to museums, libraries, etc., but also to buildings which contained movable cultural property (collections, furniture, etc.) and which have been made easy of access by the collapse of a wall or the opening of gaps. Note also monuments from which valuable decorative components have been detached by the earthquake and have become easy to take away: sculptures, woodcarvings, etc., which are still in place or have fallen among the debris.
- E. Movable property to be evacuated. Since placing monuments under guard is only a short-term measure, identify cases in which all movable property needs to be removed from the monuments for more effective protection. Note any nearby buildings which are intact and which might provide shelter for this movable property.

- F. Temporary covering needed. Identify monuments where fragile, non-removable works need to be protected by a temporary fixed covering (tarpaulin, galvanized corrugated iron or plastic roofing or boarding, etc.). This applies particularly to mural paintings exposed by the collapse of a roof, valuable parquet floors, etc., which would be quickly damaged or destroyed if left exposed to the elements (especially rain). Estimate the area to be covered or outline it on a plan of the monument.
- G. Monument intact. A monument cannot be placed in this category until it has been inspected in detail (exterior, interior, roof, etc.). In doubt, the best plan is to place it in category C (monument damaged) on first inspection and reclassify it if necessary after a more thorough examination.

(b) Practical organization

According to the personnel and equipment (particularly vehicles) available, the number of monuments to be inspected and the size of the disaster area - which, however, may not yet be precisely known - set up teams of two or three persons with one vehicle to a team; assign each team a specific sector, and try to send into each sector a person or persons who are familiar with it: (who know the roads and pathways, are familiar with the monuments and have personal relations with the population).

Each team should have an exact list of the monuments to be inspected in its sector, a detailed map of the sector and, so far as possible:

- a first-aid kit, hard hats and thick-soled shoes;
- a camera with film and flash;
- an electric torch with batteries;
- materials for marking monuments: paint and brushes, stencils or stickers and glue;
- if necessary, anti-theft equipment: chains, padlocks, barbed wire, pliers, hammer, nails, etc.

On inspecting each monument:

1. Note its condition in accordance with categories A, B, C, D, E, F and G (the same monument may of course be placed in more than one category).
2. Photograph the most revealing damage.
3. Mark the monument. During the critical period, various organizations (civil authorities, armed forces, fire brigade, police, Red Cross, volunteer groups, etc.) will come to clear the rubble, search for survivors, assemble casualties, organize first aid, distribute food and equipment, etc. Action will have to be taken quickly and co-ordination will be difficult and rough-and-ready at first. At this stage, there is a likelihood of unsupervised demolition, sometimes unavoidable but often hasty: to clear an access route or reduce the danger of collapse, the decision is taken to pull down badly cracked sections of wall or buildings (photo 1) which genuinely present a danger. In the case of historic monuments this practice has often been taken too far and has led to unnecessary acts of

destruction¹ which have been later regretted. As a rule other solutions are possible: for example, clearing another route, closing off an area or an exposed passage instead of demolishing the dangerous building. In order to reduce the risk of unsupervised demolition, the first precaution is to mark clearly the historic monuments protected by the Service. This, of course, will only be effective if everyone else with a job to do knows what the markings mean. During this first inspection it will be useful to visit the local authorities (town hall, police station, etc.) in order to report on the measures taken (monuments placed under guard, markings affixed), to explain their purpose and to request that all organizations that come on the scene should be instructed accordingly.

What markings should be placed on the monuments? The simplest plan is to adopt the blue and white emblem of the international Convention of The Hague (1954), which identifies the cultural property to be protected in the event of armed conflict (fig. 1).

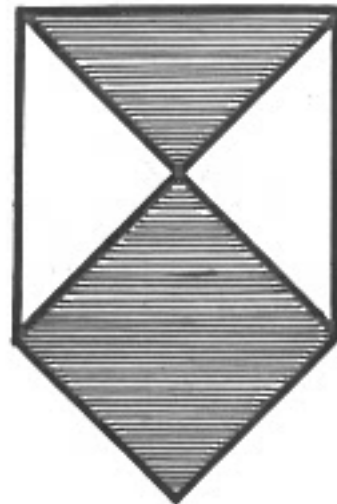

Figure 1

It should be noted, however, that the use of this emblem is reserved for countries signatories of the Convention. In countries which have not ratified the Convention a different emblem can be chosen, preferably also blue and white, provided that its meaning is explained to all the bodies concerned.

The advantage of the Hague emblem is that, as a rule, the military authorities are already informed of what it stands for. It can be painted directly on the walls of monuments (photo 14), one method being to use a cardboard stencil.

1. 'December 23, 1972. Managua, the capital city of Nicaragua, was devastated in a few seconds, and thousands were killed. For the first time, enormous amounts of international aid poured in, coming from all over the world and covering the needs of the embattled population. Along with the international aid, the bulldozers also arrived to begin a systematic demolition campaign and cancelled forever the history, the character and the image of the city.' Donald del Cit, International Centre for the study of the preservation and the restoration of cultural property, Rome, 1977.

Another solution - provided that advance preparations have been made (see chapter 10, section (d), paragraph 5) is to affix to the walls of monuments printed stickers prominently displaying the same emblem (fig. 2) with a warning message in the local language or languages. It is recommended that any such stickers should show the address and telephone number of the service responsible for each monument.



Figure 2

4. Organize the Guard Service immediately wherever it is found to be needed. If guards belonging to the Service are available locally, explore with them the best way to organize it. Depending on the particular situation and what is feasible, arrange for gaps to be filled by fences and barbed-wire enclosures, have doors and windows secured with padlocks and chains, shutters boarded up, etc. Organize watchkeeping, day and night rounds and, in important cases (valuable collections), assign one or more guards to the monument full-time. It is dangerous to house guards in buildings that are unsteady or even slightly damaged: there is always a danger of collapse, especially in the event of an aftershock. A better solution is to house them in temporary quarters (tent, caravan, motor vehicle, hut, etc.) outside, in front of the most vulnerable access routes and far enough from the building (at a distance equal to take its height) not to be buried under the debris if it collapses.

If guards belonging to the Service are not available locally, efforts should be made to obtain personnel from the local authorities (town hall, fire department, police, etc.) or to enlist volunteers (hence the importance of team members' personal contacts among the inhabitants of the sector under inspection). This will often be a difficult matter: in a major catastrophe, all able-bodied persons will already have been mobilized to dig out and rescue the victims.

5. Immediate evacuation of movable property. If Guard Service can be organized wherever it is needed, do not begin evacuating movable property during this first inspection except in dire emergency (objects of exceptional value, immediate grave danger, etc.) or where there are only a very few items to be removed. If it is only a question of a few exceptional objects, the inspection team will take them directly to Service headquarters after having completed an evacuation form, labelled the object (see below) and taken a photograph showing each object in the position in which it was found. If the objects in immediate danger are more numerous, move them to the nearest shelter after photographing them in situ. Prepare an accurate list of the objects moved.

2. Information

As soon as all the teams have returned to the Service, a first general inventory is drawn up, complete with figures showing for example:

number of monuments.....	148
number of monuments totally destroyed.....	15
number of monuments partly destroyed.....	21
number of monuments damaged.....	107
number of monuments to be guarded.....	17
number of monuments to be evacuated.....	15
number of monuments to be covered.....	9
number of monuments intact.....	26

This first inventory is immediately communicated to the authorities concerned (local, regional, national, federal). A more detailed analysis (condition of the best-known monuments, area to be temporarily covered, number and types of objects to be evacuated, etc.) will be made as soon as possible on the basis of the list of protected monuments and the notes taken by the inspection teams; this analysis in its turn will be communicated to the authorities along with the photographs taken during the inspection and a statement of the most urgent requirements of personnel and equipment (transport, vehicles, packing materials, light materials for temporary covering, etc.).

The director of the Service should also inform local organizations and the population about the measures taken and the problems faced. During the critical period, as we know, the radio is often the only means of communication available and the population, particularly in isolated villages, can learn about the situation and receive instructions only through battery-operated transistor radios. The Service will sometimes have to ask for broadcasting time on regional transmitters in order to explain to the population of areas not yet accessible to its members such matters as the surveillance and guarding of movable cultural property and the need to avoid any unnecessary demolition. It is also possible to give notice that a specialized team is en route to an isolated sector.

During the first few days co-ordination meetings are generally held in order to organize rescue operations and assign priority tasks. It is desirable that a senior official of the Service, if possible the director, should attend at least

some of these meetings in order to submit the results of the first inspection, report on the measures taken and explain the purposes and consequences.

3. Evacuation of movable property

Placing a guard on damaged monuments which contain movable cultural property (art objects, pictures, books, miscellaneous collections, archives, furniture, carpets, etc.) is an immediate measure to prevent looting, but as soon as possible such movable property should be evacuated to a safe place to preserve it from being damaged by the elements (rain, snow, frost, etc.) and from the danger of further collapse in the event of an aftershock. Furthermore, a number of these objects will have been damaged during the earthquake (for instance, pieces of pottery that have fallen down), and it is often discovered on such occasions that art objects housed in isolated or secondary monuments (country churches, old houses, temples, monasteries, castles, etc.) were in a poor state of preservation even before the disaster and require specialized treatment or repairs. The evacuation of movable property to a safe place, or safe places, should therefore be organized as soon as possible and supplemented by arrangements to use or set up a conservation service (treatment laboratory, supervised storage) manned by competent specialists.

(a) Selection of reception centres

The evacuation arrangements will depend closely on local conditions, and can be described in this handbook only in very general terms. The operations will vary widely according to the size of the disaster area, the availability of transport and freedom of movement, the monuments to be emptied and the number, nature and fragility of the objects to be transported. Efforts will, of course, be made to enlist the support of existing institutions: if there are one or more reception centres already provided with specialized staff and equipment in the vicinity of the damaged monuments, the best course will be to send the evacuated property there. These reception centres may be either safe buildings which are situated in the disaster area, but which have stood up well to the earthquake and can be relied upon to withstand any aftershock (anti-earthquake construction), or institutions situated outside the disaster area.

Sending objects to existing institutions presupposes that the consent of their management has been secured in advance and their receiving capacity assessed. This course generally entails dispersing the objects: books are sent to a library or regional archive, collections to specialized museums and so on.

However, this course is not always open and objects often have to be evacuated to improvised shelters. If there are only a few objects to be moved, an adequate shelter can often be found in the immediate vicinity of each monument: a well-constructed modern building that has stood up to the earthquake, or a building of flexible and therefore not very vulnerable construction, such as a metal-framed industrial storage shed. In such cases it may be necessary to place the receiving building under guard.

If, on the other hand, there are a great many objects of different kinds to be evacuated, it will often be preferable to seek a suitable place of reassembly further afield, outside the disaster area and a reasonable distance from the monuments - though it is better to move the property 50 or even 100 km further than to evacuate it to buildings which are liable to be destroyed in their turn by an aftershock. At this reassembly point a specialized team made up of Service personnel, possibly supplemented by reinforcements from neighbouring regions, will make an inventory and a diagnosis and apply the first measures of preservation. Since, as a rule, no storage system - shelving, stacking cabinets or the like - is available to begin with, it is to be expected that the objects will first have to be spread out on the

ground, when possible on a bed of sand. A large sheltered surface is therefore needed, preferably at ground-floor level.

(b) Practical organization

The evacuation should start as soon as the reception centres have been selected. Here again, the practical arrangements will depend on the magnitude of the task and the facilities available. When there are a great many monuments to be emptied and a great many objects to be moved, a list of priorities should be drawn up on the basis of the relative value of the collections and the imminence of the risk to each monument.

Sometimes the Service will have suitable vehicles (utility vans, cross-country vehicles) and packing materials (plastic bags, foam, straw, etc.), but more often outside bodies (civil or military authorities, voluntary organizations or private firms) must be approached for help. In practice it often happens that substantial resources are available a few days after the earthquake: many industrial, transport and commercial firms are compelled to suspend their normal activity and it is possible to explore with them, in agreement with the relief co-ordinating body, the possibility of using their staff and vehicles.

The Service should in every case be represented both when the objects are picked up and when they are delivered.

It is essential to identify each piece exactly, and above all to avoid confusion between objects from different monuments. Before it is taken away, each object should be systematically labelled and if possible photographed in the place where it was left by the earthquake. A wise course is to use ready-numbered labels with a detachable part that can be attached to the object or enclosed with it in a transparent plastic bag, leaving the counterfoil in a book which is kept in the offices of the Service (fig. 3).

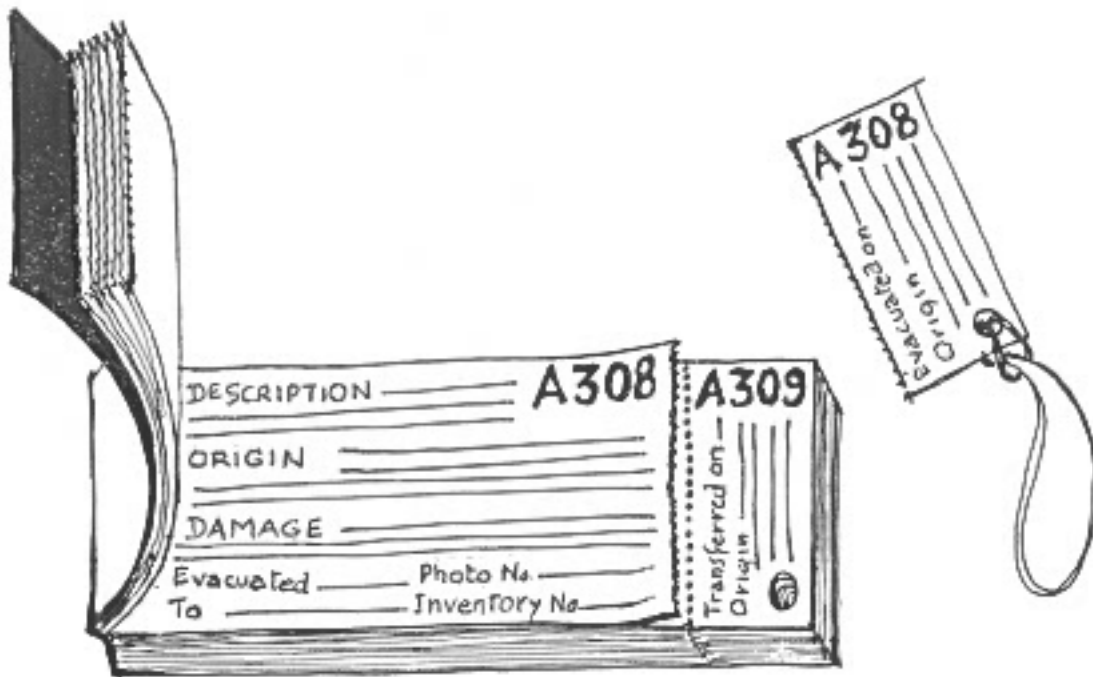

Movable property evacuation docket

Figure 3

The following information should be noted:

(a) On the counterfoil:

Number of the label (ready printed)
Description of the object (type: mask, pottery, etc.)
Apparent damage (broken into three fragments, wet, etc.)
Precise origin (e.g. XYZ Castle, 1st Floor, Room G, south-east corner, etc.)
Evacuated on (date) to (reception centre)
No. of the film, of the photographs
Inventory number (the number if any, marked on the object).

(b) On the label:

Number of the docket (ready printed)
Evacuated on (date)
Exact origin.

Collections of objects of the same kind can be grouped in batches and only the batch - e.g. a cardboard box or crate of books - need be numbered. Besides being on the label, the docket number should be marked very legibly on the outside of the box. Arrangements should be made for packages to be opened immediately on arrival at the reception centre, their contents recorded in detail, and the evacuated objects examined.

To begin with, evacuation will be confined to objects that are immediately visible or easily extricated. No systematic search will be made of the debris. Where buildings are unstable and highly dangerous, a guard will be maintained for a longer period and no attempt will be made to evacuate movable property until safeguards have been applied (chapter 6).

4. Temporary covering

On the basis of the information obtained on first inspection, the Service will have asked for the immediate dispatch of materials to provide temporary covering (tarpaulins, ropes, rafters, ladders, light covering materials such as roofing felt, corrugated metal or plastic sheets, nails, anchoring hooks, etc.). As soon as this material is available, temporary protection can be rigged. It is sometimes necessary to do this in two stages: to begin with, the most important and worst-exposed monuments will be protected with tarpaulins or plastic films, tied down and weighted (photo 2); later on this will be replaced by stouter materials (photos 3 and 5). In some cases it will not be possible to put on this temporary roofing until after the safeguards have been applied (chapter 6).

When the earthquake is followed by a rainy period, a check should be carried out as soon as possible, and first of all on monuments housing fragile works that cannot be evacuated (mural paintings, decorated or painted ceilings, valuable parquetry, etc.), to make sure the rainwater is still running off properly, even if the roof appears to be intact. Gutters, spouts and drainpipes may be clogged with debris (for instance if some of the chimney-stacks have collapsed); it will then be necessary to clear them, or perhaps to make temporary arrangements to drain off the water by a more direct route.

Wherever practicable, efforts should be made to deflect the run-off from the damaged monuments and keep it from permeating the debris piled up at the foot of the walls, especially inside the buildings. The normal drainage system (sewerage) may be out of action. A temporary system must then be improvised according to the nature of the terrain (taking advantage of a natural slope, ditches, streams, etc.).

5. Damage assessment

By this stage the first emergency measures - protection against looting, evacuation of transportable property, draining off water - have been or are being taken. Now the results of the disaster must be accurately assessed in relation to each monument, for the purpose of:

- (a) identifying any weakened parts and unstable components that will have to be safeguarded as soon as possible;
- (b) preparing the necessary safeguards and drawing up a list of requirements of personnel and equipment;
- (c) giving the authorities more exact information concerning the damage done by the earthquake.

This calls for a more thorough inspection of each monument. The damage assessment will be greatly facilitated and much more accurate if a set of drawings, or even sketches, of each monument are available for reference when it is being inspected.

(a) Behaviour of the masonry

In normal times, buildings are subject to gravity: that is, to vertical acceleration at a constant rate. They have been constructed to resist this acceleration so that it produces in the masonry only compressive stress (on walls, pillars, columns and vaults) and to a lesser extent bending stress (on lintels, beams and brackets). More severe bending stresses have as a rule made it necessary to use wooden components (beams, joists and floors).

In an earthquake, buildings are suddenly subjected to an erratic acceleration, transmitted by the ground and changing in rate and direction several times a second. The horizontal components of this acceleration are the most dangerous, for they submit the structure to horizontal stresses for which it is not designed, and subject the masonry to tensile stresses which it cannot withstand. Moreover the simultaneous vertical components of the acceleration momentarily reduce or nullify the effect of gravity and hence the compressive stress which ensured the cohesion of the masonry and would have enabled it to withstand the horizontal accelerations more firmly. The destructive effect of the tensile stresses is thus increased, with the result that either cracks of varying width and depth appear or the structure breaks up or even collapses.

Examples:

1. A masonry wall

(a) Case of maximum horizontal acceleration crosswise (fig. 4)

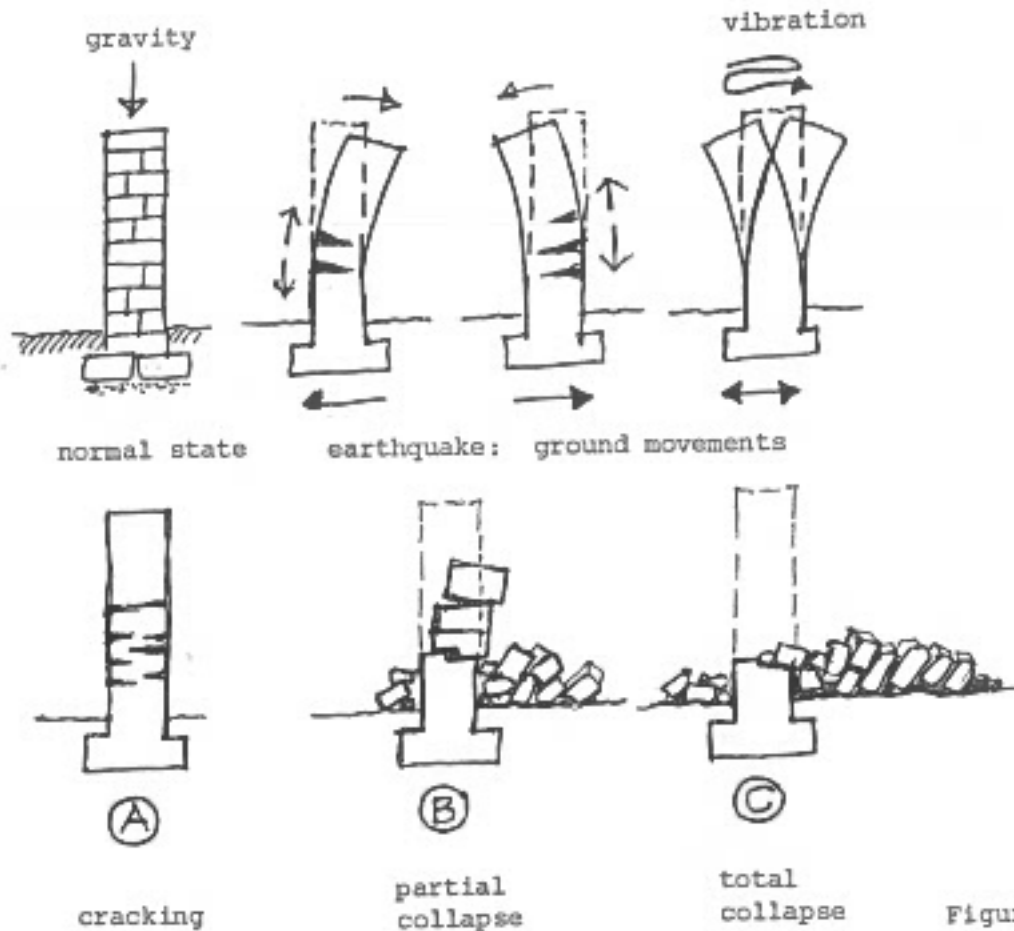

Figure 4

(b) Case of maximum horizontal acceleration lengthwise: depending on the characteristics of the wall (dimensions, proportions, method of construction, strength of the materials and especially of the binding mortar, etc.), the wall may either vibrate as a whole (fig. 5 and photo 6) or split into several fragments, each of which will respond severally and independently to the seismic vibration set up by the ground (fig. 6, photos 7, 8 and 13).

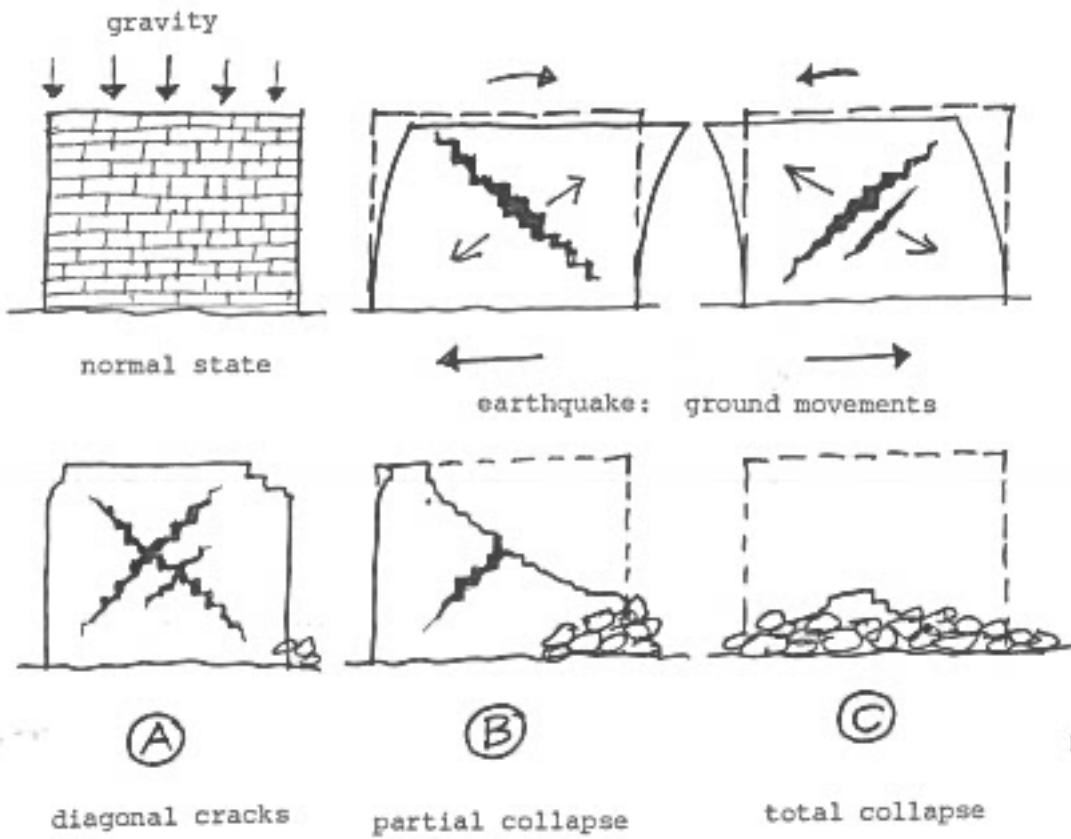

Figure 5

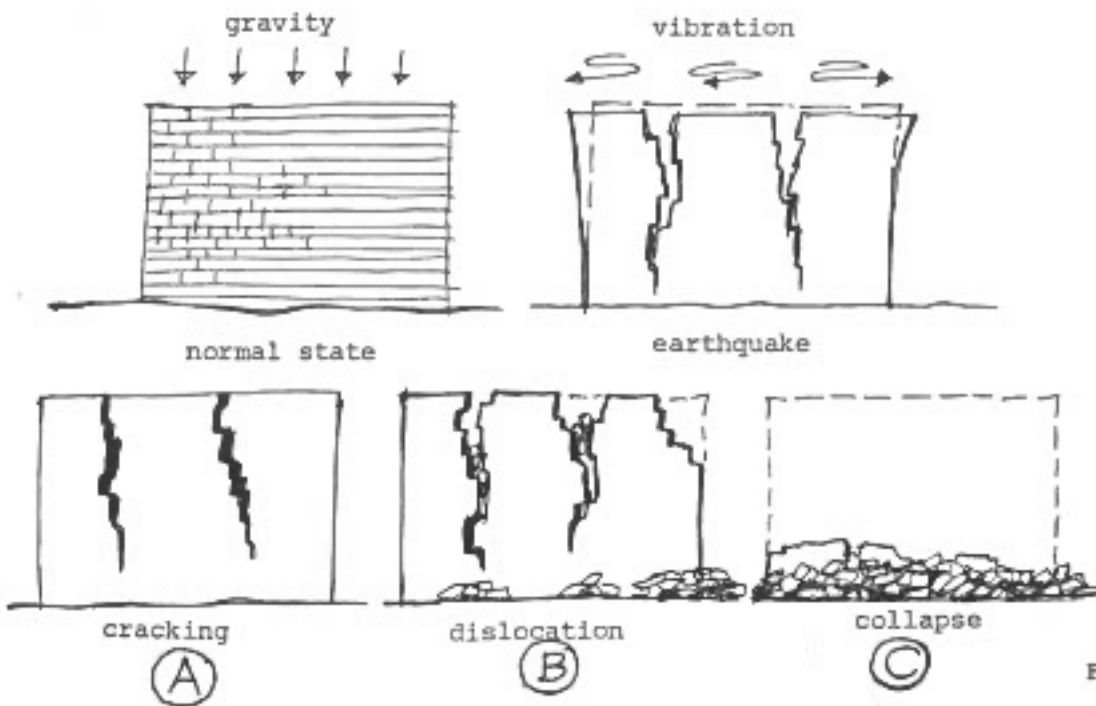
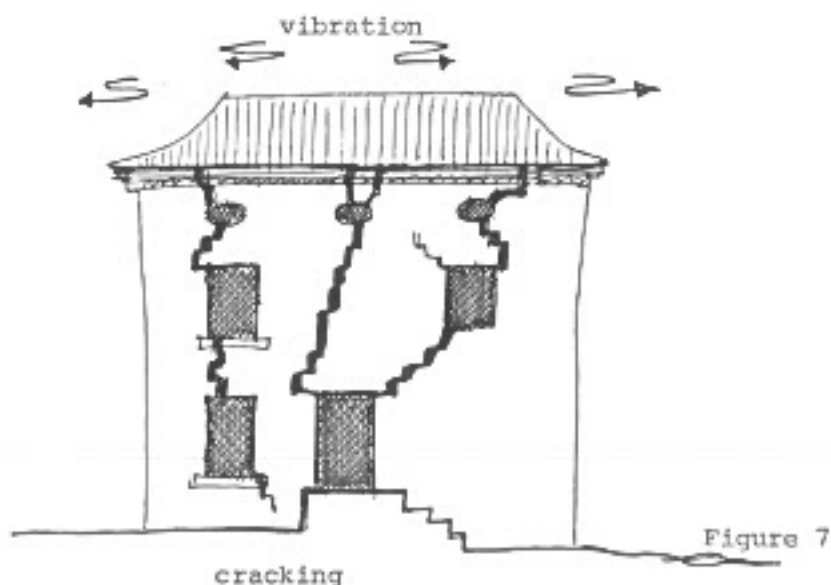

Figure 6

But a wall is seldom of uniform structure and rarely stands alone. The openings in particular are weak points, and the cracks, which run along the lines of least resistance,¹ generally converge on the doors and windows (fig. 7, photos 7, 8 and 13).



2. Vaults

During the period of vibration, each load-bearing wall tends to vibrate independently, in accordance with its own characteristics. The phases in which the walls are pulled apart nullify the compressive forces that kept the materials of the vault together, resulting in longitudinal cracks (A), deformation of the vault (B) or its collapse (C) (fig. 8, photos 10, 11 and 21).

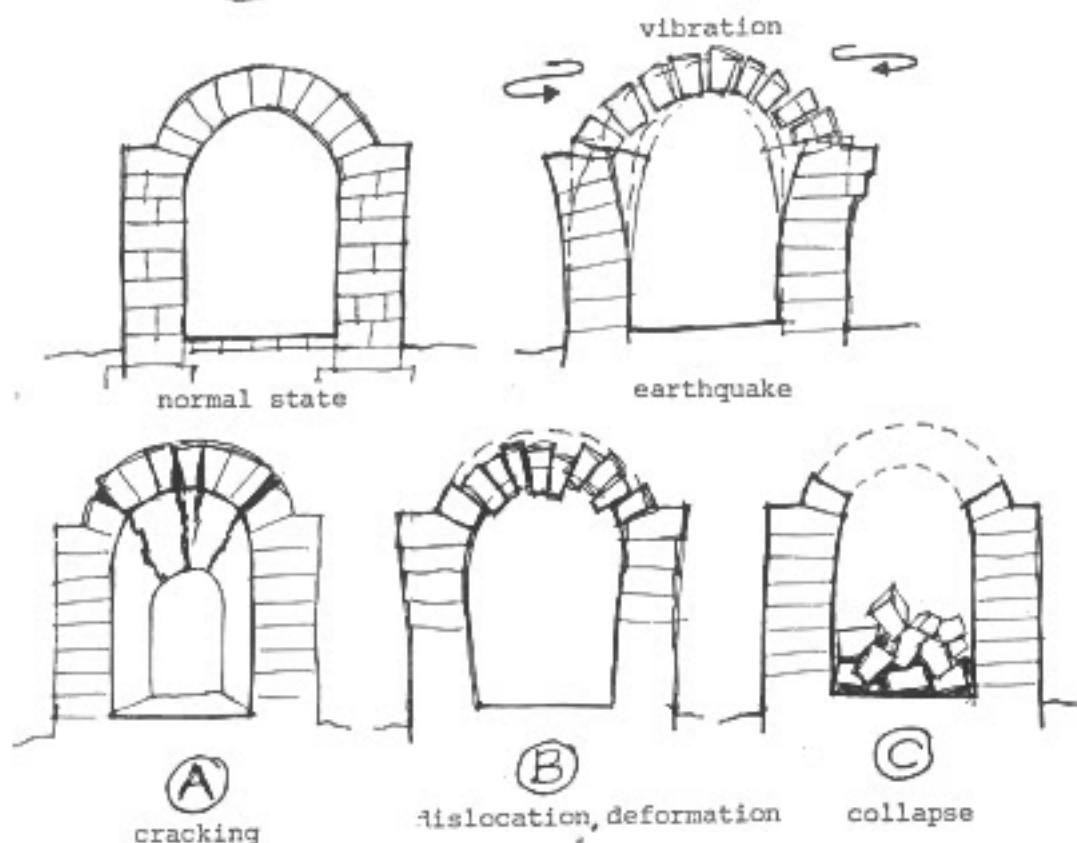

Figure 8

Vault

1. To separate two postage stamps, we pull them apart (we exert tensile stress); the tear follows the perforations (line of least resistance). The same thing happens when an earthquake rends a wall: the crack runs from window to window, from one weak point to another.

3. Floors

When the floor beams and joists are not deeply set into or anchored in the walls, the temporary separation of the walls during certain phases of the vibration can cause the collapse of the floors (fig. 9).



(a)
vibration

(b)
collapse

Figure 9
Floor

4. A single building

Depending on the quality of the structural bonds (wall corners, bond between façade and partition walls, anchorage of beams, etc.), the behaviour of buildings and of each structural component will vary. But it may already be noted that each wall tends to react in accordance with its own dynamic characteristics, and consequently to be separated from the other components by dislocation of the structure (fig. 10, photos 7, 8, 9 and 13).

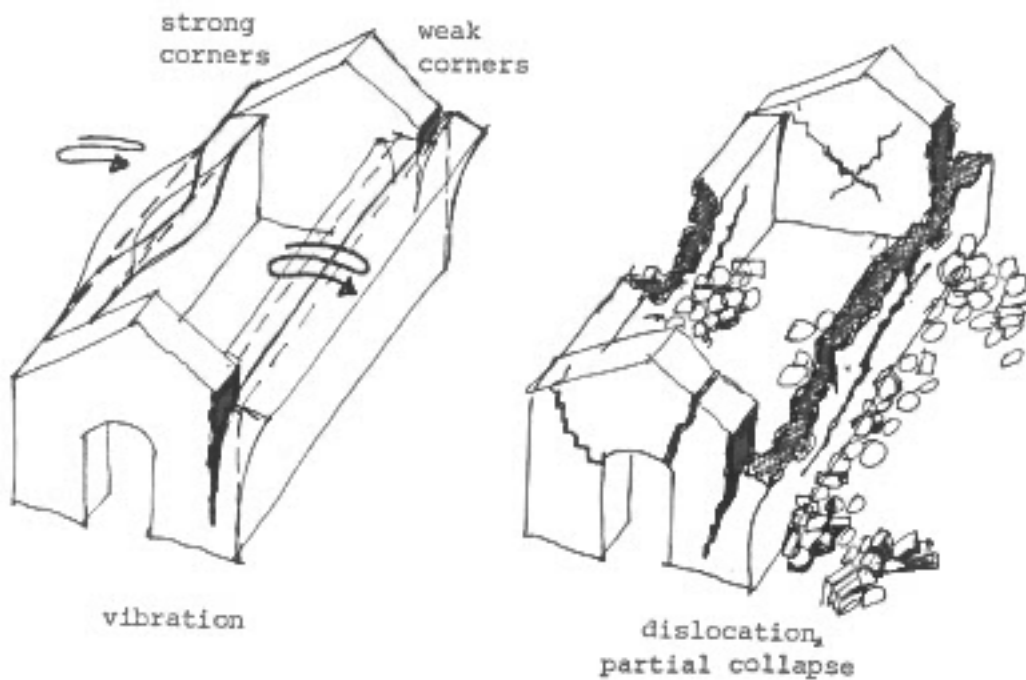

vibration

dislocation,
partial collapse

Figure 10

5. Damage to foundations.

Damage to the foundations, even when it is extensive, is not always apparent on first examination (especially when the base of the walls is hidden under the debris left by the collapse of the upper parts), and must therefore be inferred by observation of the structure.

Such damage is evidenced, in particular, by a general tilt of structural components (walls, pillars) starting from the base; this indicates either a localized crushing of the foundation or bottom courses (fig. 11a, photo 12) or the settling of the ground beneath the foundations (fig. 11b, photo 8).

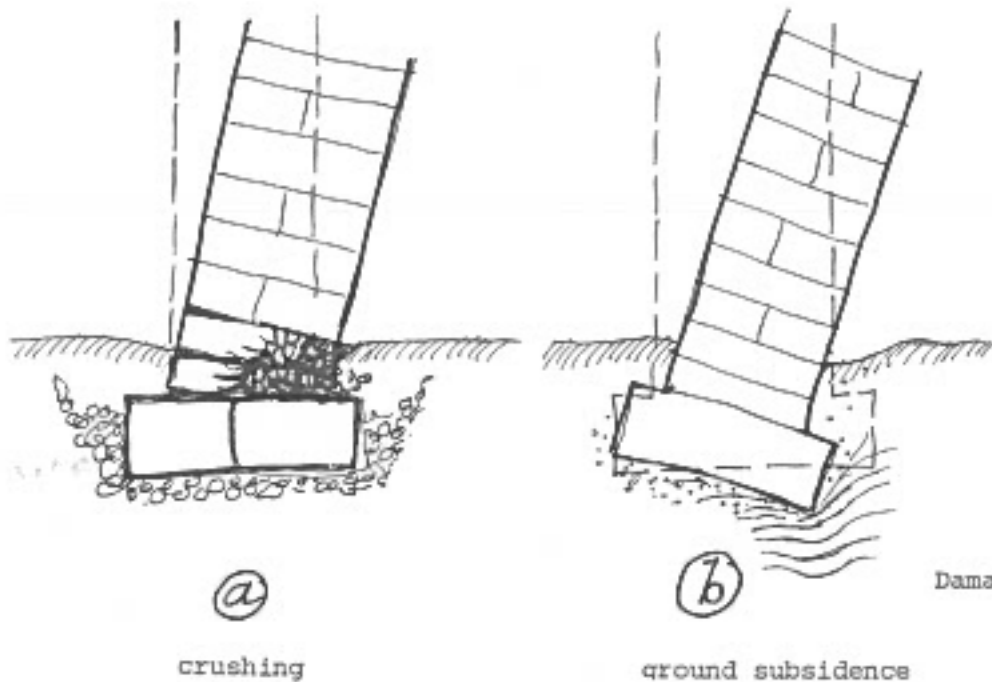

Figure 11
Damage to foundations

Disruption of the foundations is also likely where the cracks reach the ground, especially if the fabric is lower one side of the crack than the other (fig. 12.)

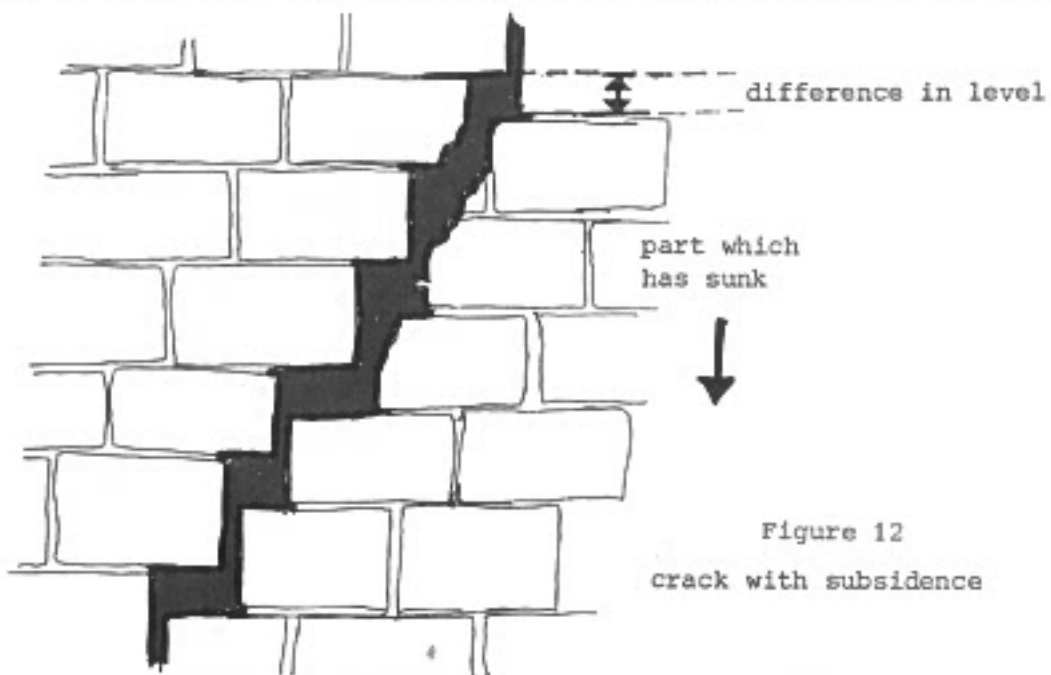

Figure 12
crack with subsidence

Further evidence of foundation damage is given by cracking or deformation of the ground floors, particularly if there is a difference in the floor level on either side of the crack (fig. 13a) or a marked tilt of the floor (fig. 13b).

Damaged foundations

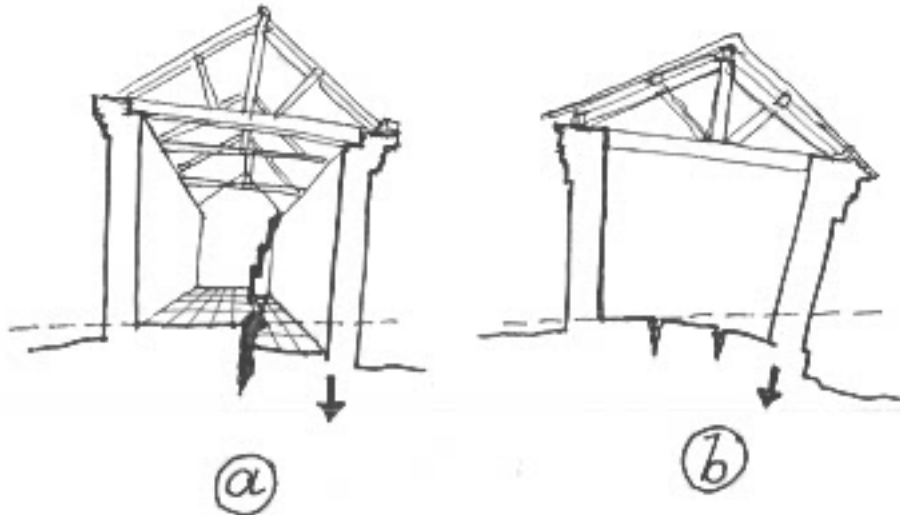

Figure 13

Damaged foundations increase the danger that a structure may subsequently collapse even if there is no aftershock, and they make the work of preservation more complex and laborious. When foundations are believed or known to be damaged, a first step to take is to place dated plaster telltales (fig. 14) across significant cracks; a break in the telltale will indicate that subsidence is still in progress, and will afford a means of measuring the subsidence rate. If a gap opens in the telltale, emergency action must be taken to apply temporary safeguards (shoring trestles, etc.) to the structure; the appropriate measures must be chosen and applied only by professionally qualified personnel.

Telltale on crack

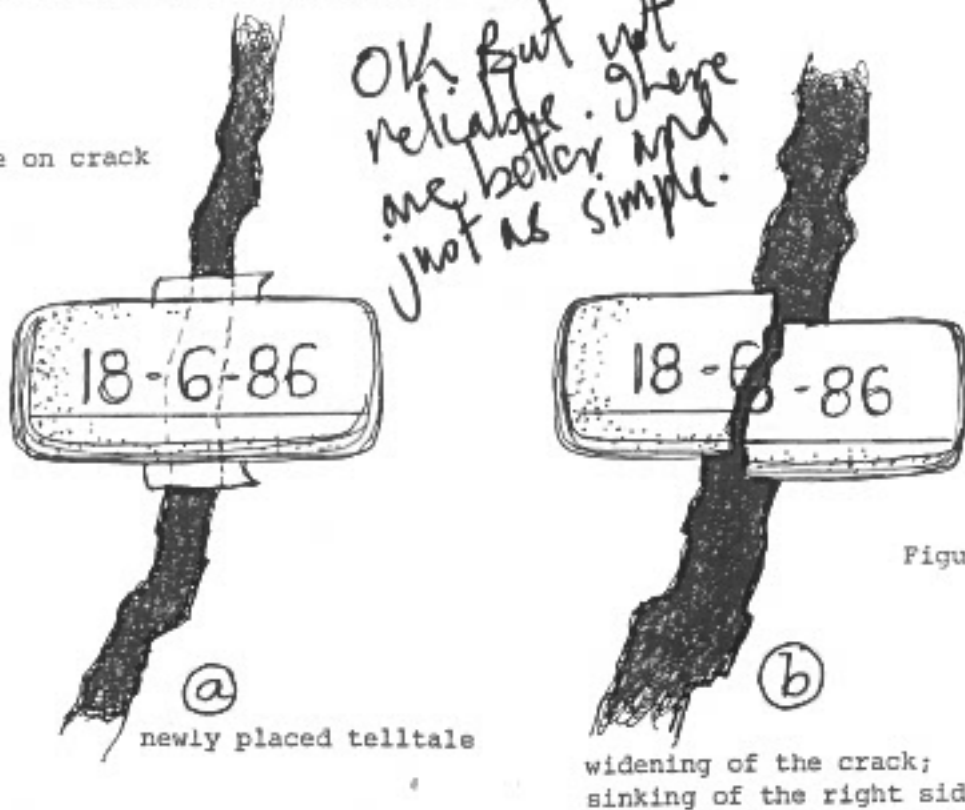
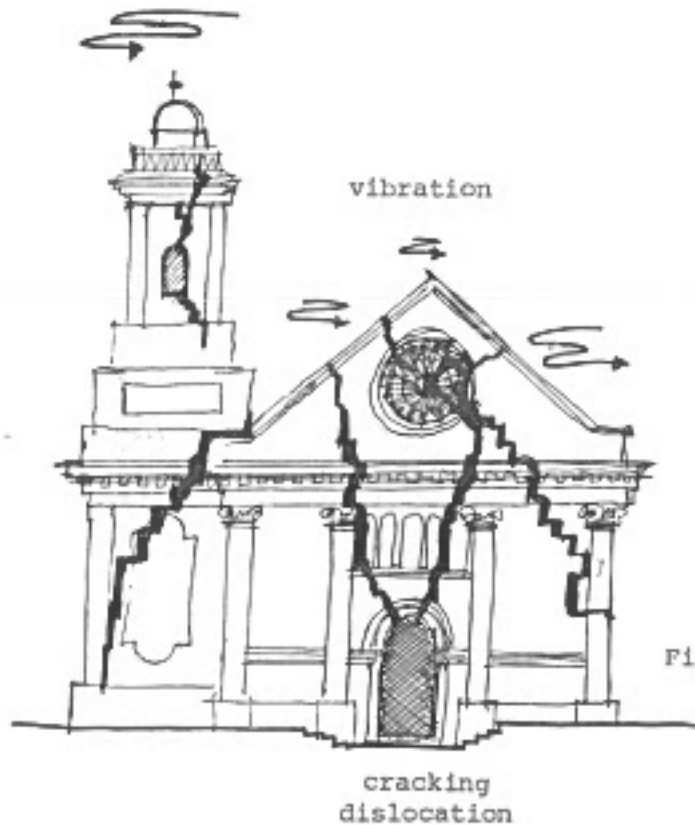

Figure 14

newly placed telltale

widening of the crack;
sinking of the right side

A monument's behaviour is, of course, more complex than these elementary figures, but the principle still holds good: under slight acceleration, the structure vibrates as a whole. When the seismic acceleration becomes too severe, every structural component - every wall, every pillar, every block of masonry and, in the extreme case, every stone or brick - tends to vibrate independently, in accordance with its own characteristics (mass, form, rigidity, natural frequency, etc.). Tensile stresses then appear, first causing cracking of the masonry (fig. 15), and dislocation or collapse in more serious cases.



The three stages indicated in the preceding figures - (A) cracking, (B) dislocation or partial collapse, and (C) total collapse - represent a progressive worsening of the damage, which depends on the initial construction technique, the state of preservation and the characteristics of the earthquake (maximum acceleration, duration of active period, frequency of vibration, etc.). For example an earthquake may produce state (A) in a well-built structural component and state (B) or (C) in an identical component which is poorly built or maintained. On the other hand a relatively weak earthquake will produce state (A), a stronger earthquake state (B) and an even more violent earthquake state (C) in the same building.

Thus by examining the cracks in the masonry of damaged or partly destroyed monuments it is possible to analyse the behaviour of the monument and of its structural components. Above all it is possible to detect the parts which have been weakened by the earthquake and which must be safeguarded as soon as possible. Monuments may progress from state (A) to state (B) or (C), as defined above, as a result of the instability of dislocated structures, bad weather and, above all, aftershocks. To check this progression, safeguards must be applied (chapter 6).

In order to make a correct assessment of this risk, it is also necessary to distinguish several different degrees of cracking associated with damage of varying severity:

(a) Thread-like cracks in plastering. The plastering (gypsum plaster, lime plaster or cement) applied to walls and ceilings is highly prone to cracking, and fine cracks may appear in it without signalling anything seriously wrong with the masonry. Moreover it may be difficult to establish whether such cracks have been produced by the earthquake or were there already. However, they do attest to some - admittedly minor - deformation of the masonry and indicate where major stresses have developed.

(b) Wide cracks. Wider cracks indicate that dislocation of the masonry is beginning. When they appear on only one side of a wall, they are probably the result of bending stress during the vibrations, but the diagnosis may be more complex in the very frequent case of compound walls (facings and lining). Cracks which appear on both sides of a wall and follow substantially the same lines indicate more clearly the beginning of dislocation into several parts.

(c) Deep cracks with crushing of material. The presence of crushed building material (stone or brick) inside the cracks shows that, at certain phases of the vibration period, the crack has opened wide between two parts which vibrated differently from each other. There has thus been an actual dislocation, even if the crack closed up again when the vibration stopped, crushing the imprisoned material (fig. 16).

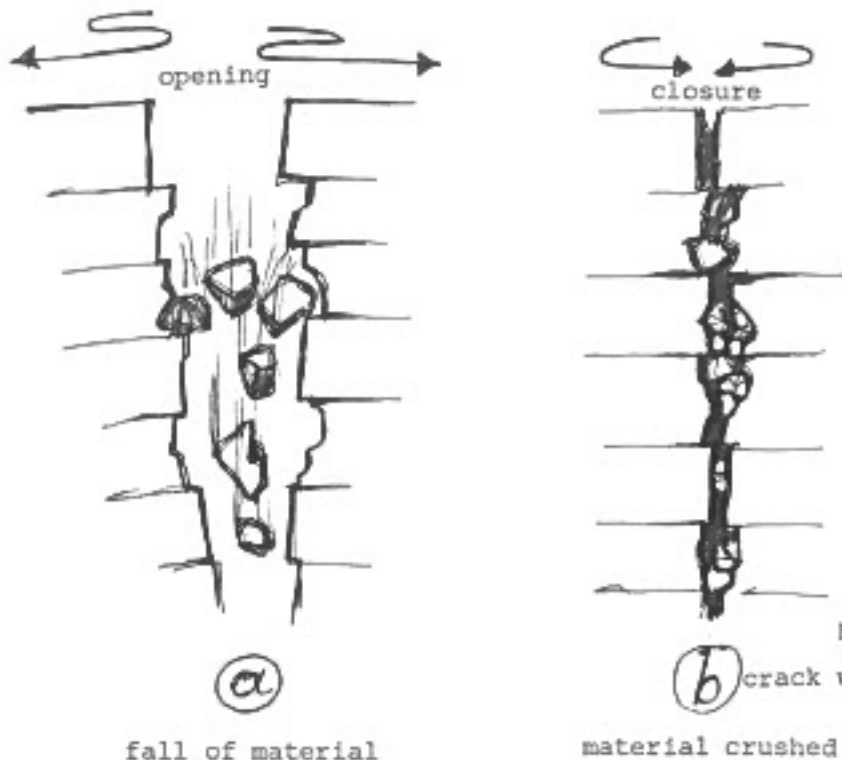

(d) Crosswise open cracks which completely split the structural member (photos 7, 8). The dislocation of the structure is plain to see.

(e) Thread-like cracks (generally a web of cracks) in the construction materials. A pattern of fine cracks in stone blocks (and to a lesser degree in bricks) indicates intense compressive or bending stress causing partial crushing of the materials; this is evidence of a serious structural imbalance (photo 12) often associated with some disturbance at foundation level (fig. 11a).

(b) Damage assessment procedure

On the basis of the results of the first inspection, each monument classified (B) 'partly destroyed' or (C) 'damaged' should be reinspected. Ultimately it will be desirable to reinspect monuments classified (G) 'intact' in order to confirm or alter the initial classification.

If there are many monuments to be reinspected, the disaster area must again be divided into sectors each entrusted to an assessment team. For this more technical assessment, however, each team should include a professionally qualified member: an architect, an engineer or a skilled technician with previous experience in the preservation of ancient buildings.

It is important that the various teams should be able to make their assessments as uniformly as possible, and hence that they should be guided by the same assessment criteria. The criteria developed for the assessment of earthquake damage in the Balkan region, which take account of the experience gained with the Montenegro earthquake (Yugoslavia, 1979), may prove useful in this respect.¹ They divide damaged buildings into six categories.

Category I - building serviceable (stability not impaired).

IA: building intact. No damage visible in structural components. There may be fine cracks in the plastering on walls and ceilings.

IB: building slightly damaged. No structural damage. Cracks in the plastering on walls and/or ceilings. Falls of plaster in patches (walls and/or ceilings). Cracking or partial collapse of chimney stacks, balustrades, pediments, etc. Damage to, partial slippage of or falls of roofing components (tiles, slates). Fine cracks in structural components.

Category II - building temporarily unserviceable, whose stability has been impaired and which cannot be reused until the structure has been strengthened.

IIA: structural damage. Big cracks (diagonal or other) in the load-bearing walls. Diagonal cracks in walls between windows. Chimney stacks, balustrades, pediments, etc. seriously damaged or collapsed. Serious damage to roofs, slippage and fall of roofing components.

IIB: serious structural damage. Wide cracks in the load-bearing walls with crushing of building materials, whether the wall is completely split or not. Wide cracks with crushing of materials in the walls between windows. Partial or complete destruction of partition walls. First signs of structural dislocation of building components or entire building.

1. See: Building construction under seismic conditions in the Balkan region - UNDP/UNIDO Project RER/015 - Working Group D - Damage evaluation and assessment of seismic resistance of existing buildings, Skopje, December 1982 (the information relating to reinforced concrete components has not been mentioned here).

Category III - building not reusable without major structural repairs. The general view is that the repair of buildings in this category is not economic and that it will be less expensive to demolish them and erect a new building of equivalent area. In the case of historic monuments, this economic criterion is secondary to the cultural or historical value of the monument.

IIIA: structural dislocation. Structural components seriously damaged or dislocated. Walls split and separated, structural assemblies destroyed. Several structural components crushed. General movement of the building. Tilting or level failure in floors and/or roof.

IIIB: partial or complete destruction. Structural components crushed or dislocated, completely or partly destroyed. Building completely or partly collapsed.

The appropriate category will therefore be recorded for each monument, either for the entire building if it is a simple monument or for its several parts. This work may be carried out far more rationally and more easily by marking the damage on a set of simplified sketches of the monument (fig. 17).

Set of simplified drawings of a monument used to record the damage observed

Figure 17

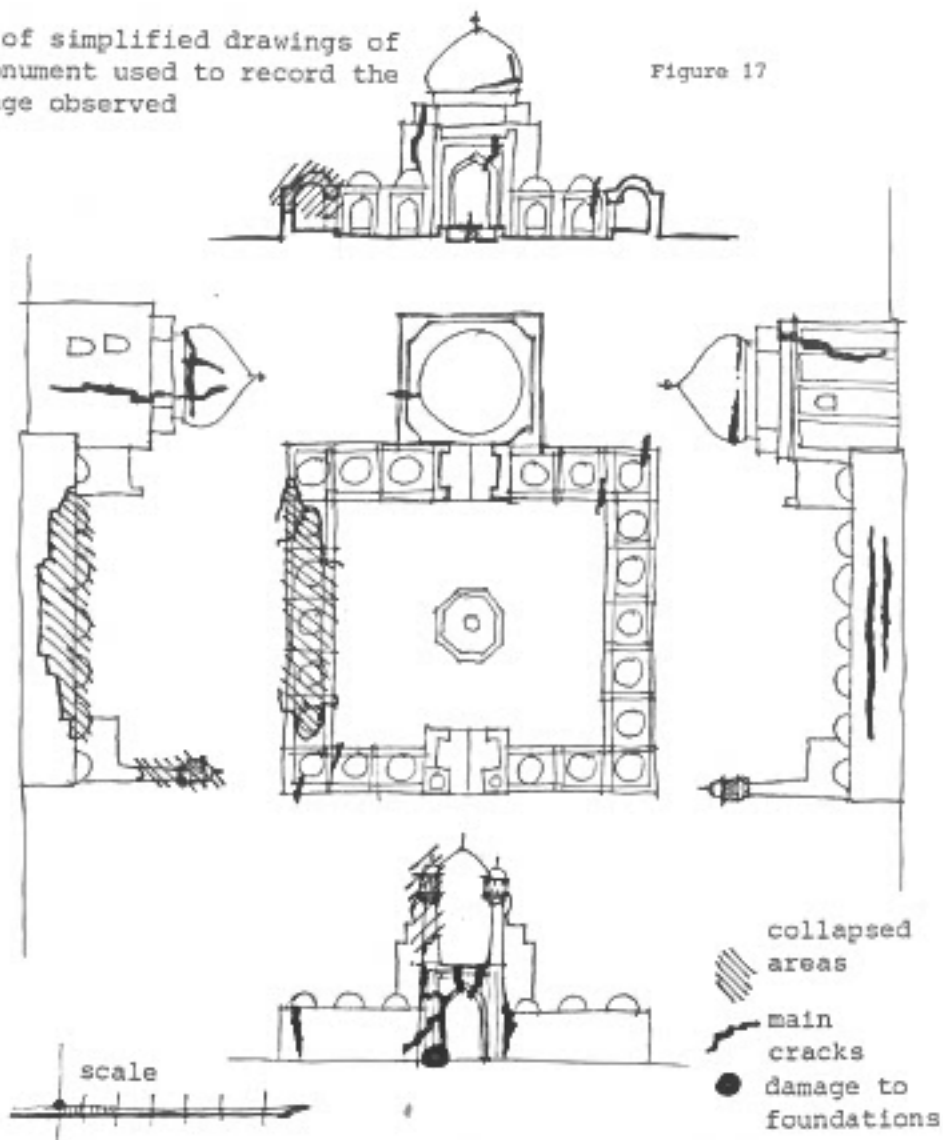

This set of sketches, or simplified drawings, can be included in a standardized damage-assessment form (one form per monument or building); the use of these forms is the best method of obtaining accurate and consistent results. The forms specially designed for assessing the damage to the historic monuments of Montenegro, Yugoslavia, after the earthquake of 15 April 1979 have proved their worth. They comprise four pages, 210 mm by 297 mm (fig. 18 and annex 1).



Figure 18

Damage assessment form
(see Annex 1)

- Page 1 - identification of the monument, area of each floor, damage observed.
- Page 2 - set of simplified drawings of the monument, showing the damage.
- Page 3 - characteristics of construction and materials, description of deformations, emergency action proposed, repair programme proposed.
- Page 4 - classification by damage category (I, II, III), estimated cost of repair, particulars of the assessment team and reference of photographs.

It is possible to have these forms printed outside the disaster area, in the capital or a neighbouring town, during the critical period so that they will be available when the systematic assessment of the damage begins. If a comprehensive survey is made with these forms, the protection of the cultural heritage can be organized efficiently at all stages: setting priorities for action, ordering equipment, distributing resources and staff, etc.

In addition to inventorying the damage, the assessment teams will take advantage of this second inspection of each monument to supplement the photographic coverage and check that the emergency measures (temporary covering, evacuation, etc.) have been properly carried out or are under way.

Colour code. The classification by damage category (IA, IB, IIA, etc.) can be painted on each monument using the colour code applied in Montenegro in 1979: green for category I (underlined once for IA, twice for IB), yellow for category II (underlined once for IIA, twice for IIB) and red for category III (underlined once for IIIA, twice for IIIB). The identification number of each assessment team is then painted on each building in the colour for its category, followed by the serial number specific to each building (photo 14).

This system is particularly recommended where a great many buildings are concentrated in a limited sector: for instance, all the houses in a historic city. It makes it easier to record the damage on the town plan, which will be an essential tool in future restoration work.

In practice the use of the colour code will not, as a rule, be restricted to the cultural heritage; it will be a comprehensive measure adopted by the authorities and applied to all buildings in the disaster area - dwellings, shops, schools, public buildings, factories, etc. - and historic monuments will be just one specific case in the general procedure of damage assessment.

6. Safeguarding of structures

The damage assessment makes it possible to assign priorities: that is, to identify the monuments and parts of buildings which have been left by the earthquake in the most unstable state and which must be safeguarded as soon as possible in order to prevent any worsening of the damage, ruin of the dismantled monuments and permanent loss of the cultural heritage.

It is not at all the purpose of these safeguards to repair the monuments, let alone restore them. This purpose is to keep standing those structures that have not collapsed, by temporarily improving structural stability in order to increase resistance to possible aftershocks and avert the danger of collapse until such time as a reconstruction policy is adopted and long-term repair, reinforcement and preservation measures can be planned and implemented - a process which takes several years.

Since the damage caused by the earthquake is chiefly due to tensile stresses in the masonry, which are set up when each structural component behaves independently, the purpose of the safeguard procedures (and, generally speaking, of the measures of reinforcement that will be applied later on) will be to restore to the buildings a minimum of structural continuity so that the structure will behave as one whole.

(a) Restoration of structural continuity

The position and direction of the cracks enable us to identify the loosened components most likely to collapse and the direction in which they are likely to do so. In this respect cracks may be regarded as a state midway between normality and destruction, a pause in the process of falling apart: they show, like a snapshot, a structure in course of dislocation.

1. Strapping

Whenever possible, the best method of safeguarding the building will be to bind it together with tight continuous straps running round it at the most critical levels: the tops of the walls, the haunches of the vaults, the floor levels (fig. 19).

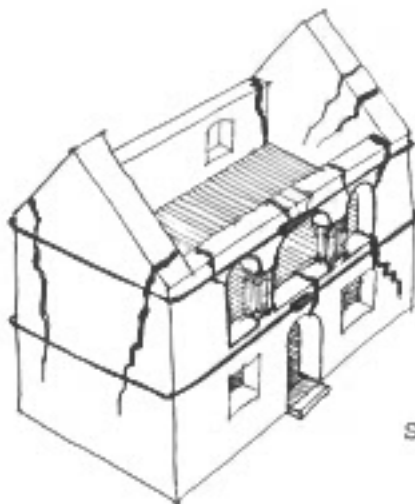
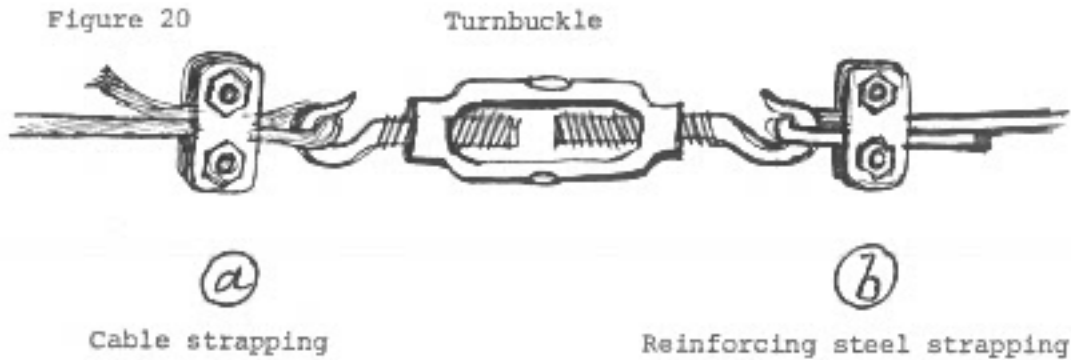

Figure 19

Strapping of a building

These straps will consist of metal cables or reinforcing steel rods, whose elasticity has the advantage of preserving a minimum of flexibility in the masonry. This is needed in order to absorb seismic energy and to conserve a favourable damping capacity. However, this elasticity (greater in cables than in reinforcing steel) has a disadvantage: at first it allows tensile stresses to develop and cracks to open while the steel is lengthening and before the retaining effect is felt. For this reason the strap must be slightly prestressed so that it will react as soon as any strain is placed on it. This can be done by using tightening devices such as the turnbuckle (fig. 20).



There are many similar devices on the market.

Another method of prestressing, easier to use but suited more specifically to reinforcing steel, is to thread the ends of the rods and tighten them up by bolting them on to angle plates. These plates must then be specially made with a single weld, so as to provide a good seating on the masonry and accurate tightening on each façade of the building (fig. 21).

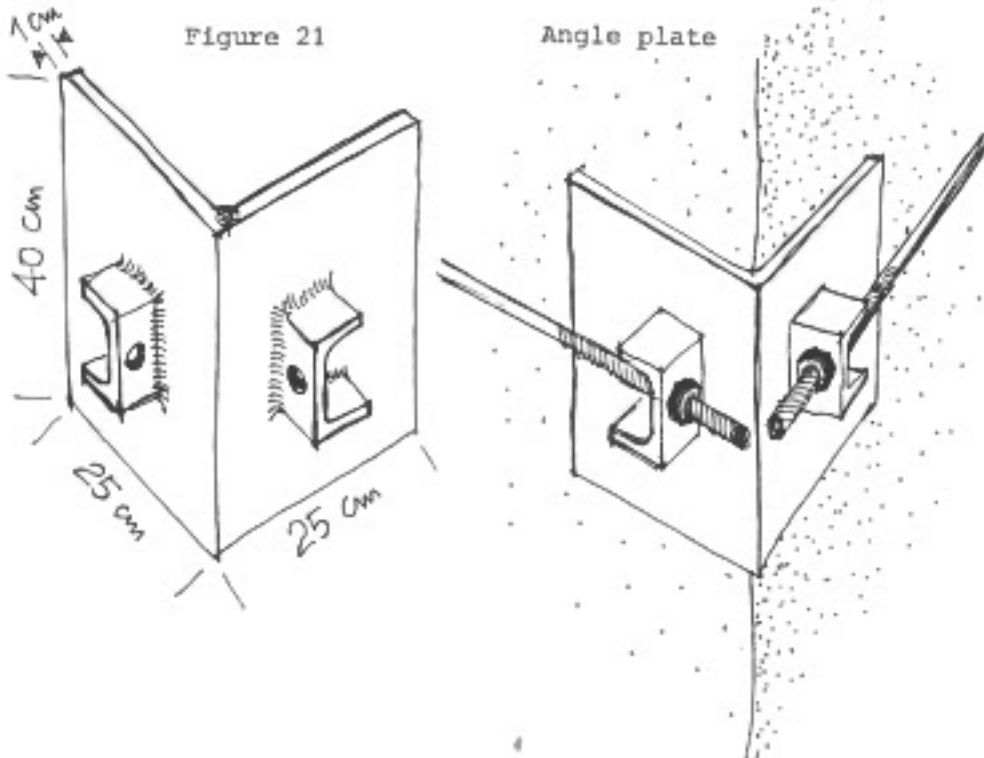

In order to provide a better seating on the masonry and to protect the architectural decoration (mouldings, pilasters, plastering, etc.) it will often be essential to insert barks of timber between the straps and the building (fig. 22).

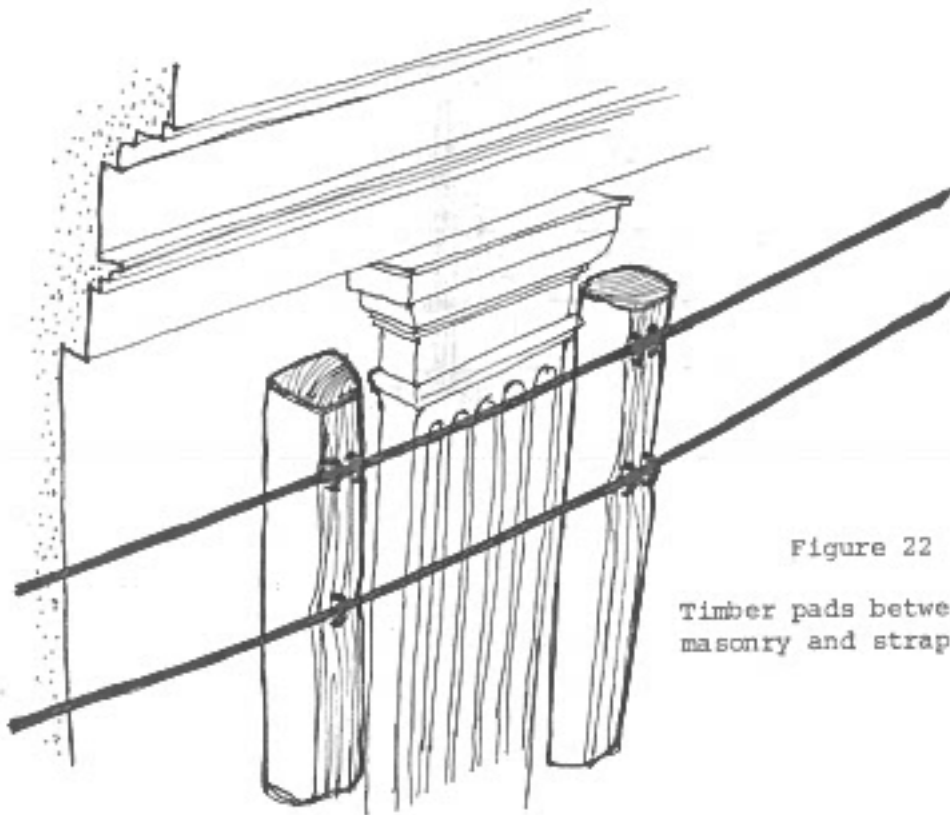

Figure 22
Timber pads between
masonry and straps

Lastly, it is always preferable to use straps (cables or reinforcing steels) of small diameter, between 10 and 16 mm. Where there is a large mass of material to be held together, it is better to fit two or three parallel straps than one stronger one: in other words, to distribute the stresses instead of concentrating them.

2. Cross ties.

Where the building is of some size and, more especially, if it is elongated, strapping alone is not enough. Cross ties must be added. The simplest solution is to use the windows, but this is generally risky because the level at which the ties are positioned is unsatisfactory. It is accordingly necessary to place vertical pads between the walls and the ties and to position the ties symmetrically in relation to the floors (fig. 23). Wherever possible, the aim will be to place the cross ties symmetrically in relation to the compressible components that divide up the structure: floors, cross-walls, diaphragm arches, etc.



Figure 23

3. Bracing of openings.

Even in normal times, the openings are weak points in a structure. By the time an earthquake is over, they have attracted cracks and become a potential factor for collapse. To supplement the strapping, the openings should be braced in order to make the walls as homogeneous as possible.

The traditional method of bracing with balks of timber can be used (fig. 24, photos 15 and 16).

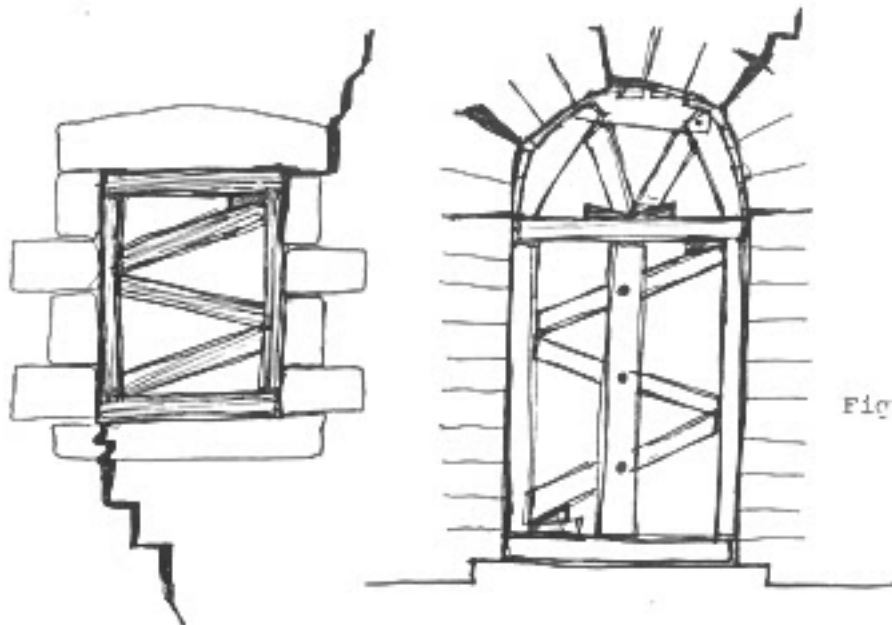

Figure 24

But the simplest solution will often be to wall up all openings systematically (fig. 25) with bricks or cement blocks bound by gypsum, lime mortar or, out of necessity, by a low percentage cement mortar. This method has the additional advantage of blocking or restricting access to the monument (photos 16 and 17).

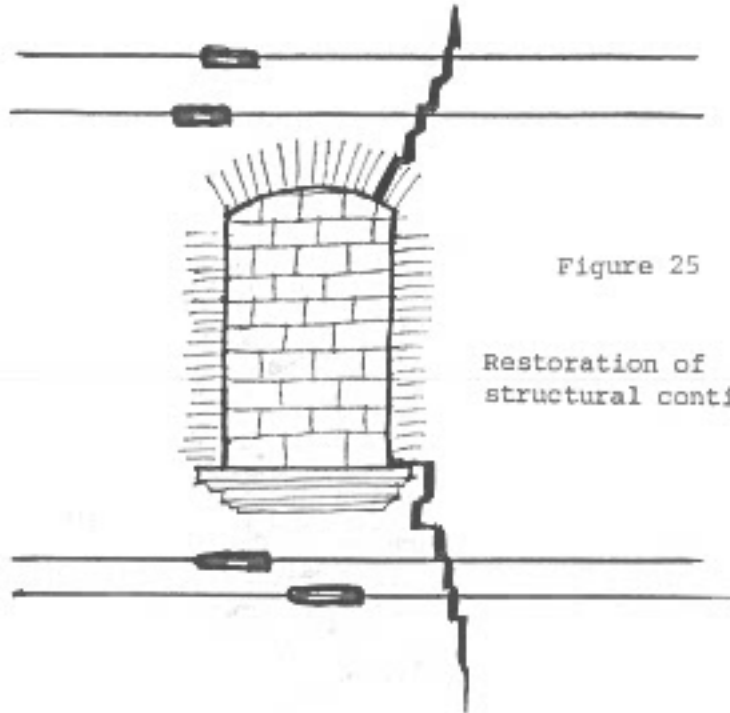

Figure 25

Restoration of structural continuity

Walling up openings and strapping the building

In the event of partial collapse, it will often be necessary to restore the physical continuity of the wall before the straps are fitted; this is done either by filling the gaps or replacing collapsed parts with a frame structure (braces or horizontal shores) or by temporarily rebuilding the ruined wall (fig. 26).

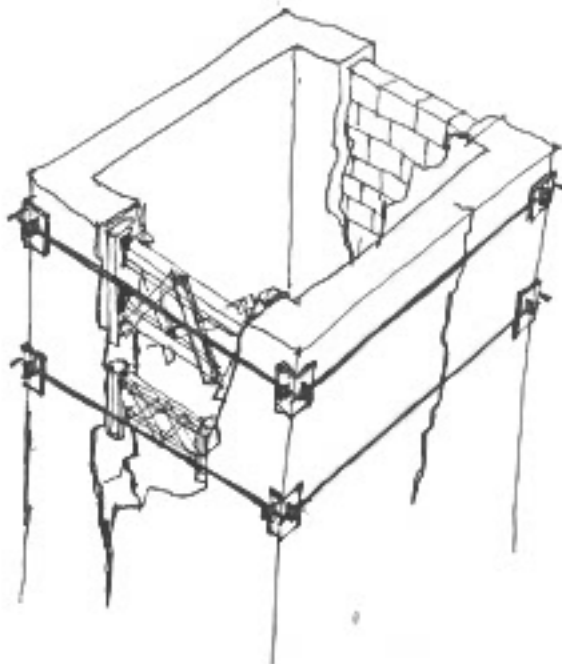

Figure 26

Restoration of structural continuity

By a combination of walling up openings and fitting straps, even structures pierced by many openings can be stabilized (fig. 27).



Walling up of openings and strapping

In the case of damaged, severely cracked or profoundly dislocated monuments, a combination of these mutually complementary methods (straps and cross ties, walling up or bracing of openings and gaps) may restore structures to the desired cohesion - indeed, it generally makes them stronger than they were before the earthquake: resistance to aftershocks is greatly enhanced and, with stability restored, work on the monuments can proceed under acceptably safe conditions.

Except in very simple cases (small, very massive monuments), strapping alone is inadequate; it may even be dangerous owing to the false impression of security that it gives. The same applies to the bracing of openings: these measures are effective only if applied together. In the interests of workers' safety, operations on each monument should so far as possible be carried out in the following order:

1. fitting straps, not tightly, around the outside;
2. walling up or bracing up the openings and gaps;
3. prestressing the steel components by tightening the straps and ties.

(b) Shoring

Traditional shoring procedures, with the props resting on the ground outside the buildings, should be used only when straps and ties are inadequate or cannot be fitted. These props need to be anchored on the ground, and this is often difficult to achieve effectively. In particular, in the event of an aftershock they transmit the ground movement directly and abruptly to the upper parts of the structure - which is then at the peak of the vibration phase - and may act as battering rams, causing the destruction of the features they are supposed to support (photos 18 and 19). As a rule, shores are needed only in the event of pronounced tilting (where the building tilts en bloc), to relieve the foundations or to support isolated structures with little grip on the ground (photo 20).

On the other hand, means of vertical support (shores, trestles or bents) are needed to relieve disrupted pillars or wall sections that are under heavy load, to improve the weight distribution in buildings with unsteady foundations or to support unstable members such as a broken lintel, a loosened floor or deformed vaulting (photo 21). Installing temporary support of this kind is always a demanding task - even more so in times of seismic activity - and should be entrusted to highly qualified specialists.

(c) Dismantling

Fragile structures which have been severely shaken, especially small-scale decorative features, will often have to be dismantled and the materials stored in a safe place. The operation should be amply covered by photography; the dismantled components (building stones in particular) should be numbered in indelible paint before removal and the numbers recorded in a notebook. The components should be stored in a logical order to facilitate reassembly (fig. 31). Dismantling such structures is more difficult where the masonry is of brick, especially if the bricks are covered with plaster mouldings or sculpture. The aim should be to remove components as nearly as possible in one piece, consisting of several bricks still bonded by their mortar.

(d) Timber frames

Timber frame structures are often more earthquake-resistant because of their greater flexibility and the bracing built into them to withstand horizontal wind pressure. If the seismic acceleration is too great, however, the wind bracing may give way, destabilizing the entire structure so that it tilts or collapses.

Safeguards for damaged structures will include temporary bracing (metal tie-rods, wooden struts, etc.) to stabilize the tilt (fig. 28). In more serious cases the wisest course is often to dismantle the structure and place the structural timber and covering materials in store.

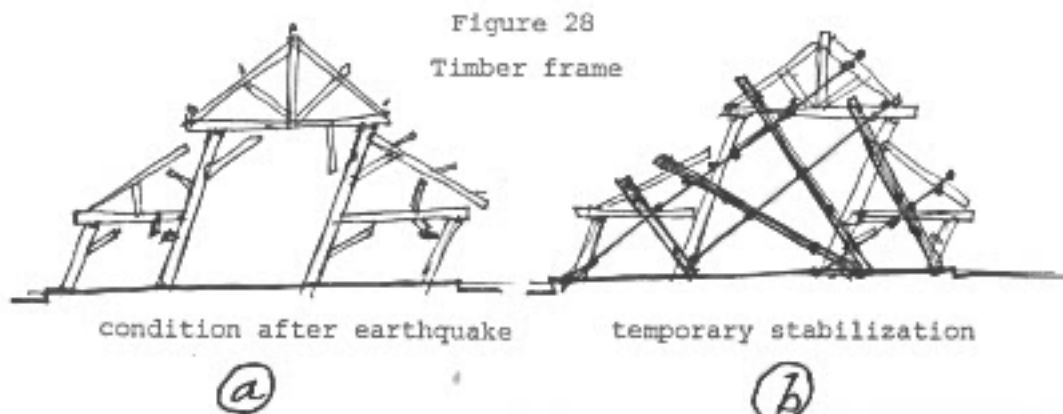

(e) Roof repairs

The fitting of temporary coverings to protect fragile features has in principle been completed (see chapter 4). In other cases, once the structures have been provisionally stabilized, the roof must be repaired in order to keep the rain out and prevent it from seeping into the masonry or damaging the structural members (timbers, floors, staircases, etc.). Depending on the type and condition of the roofing, use should be made either of light temporary materials (corrugated or ribbed metal or plastic sheeting) or of salvaged original materials (tiles, slates) if these are available. It is always preferable, however, to reduce the weight of the top parts of the building in order to relieve the weakened structures.

(f) Protection of non-transportable items

Temporary protection must sometimes be provided for non-transportable items of exceptional value (altars, tombs, statues or groups of sculpture, etc.). In the initial (critical) period, sandbag protection is an acceptable measure. Thereafter effective protection against falls of overhanging masonry may be provided by a shelter stoutly built of timber or metal with adequate bracing and designed to resist crushing (fig. 29) covered with boards, at least 25 mm thick.



Figure 29

Protection of a non-transportable statue

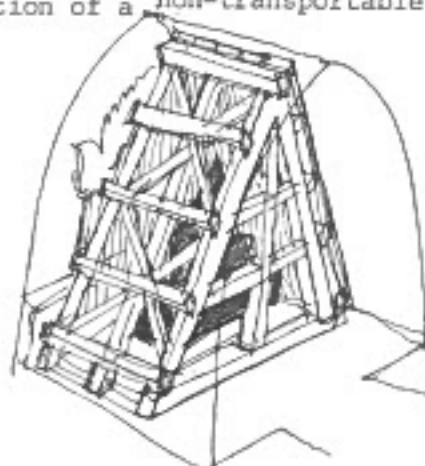

7. Removal and sorting of debris

Once the damaged monuments have been temporarily stabilized, it becomes much less dangerous to enter them or to work near them. The time has come to sort the debris of the collapsed upper parts.

If the personnel had been available, this operation could have been started earlier, beginning for example with monuments that had been completely destroyed and wherever the structures still standing presented no danger to the workers or, conversely, where accumulated debris placed the monument at risk: for example where the entire vault had collapsed and the debris exerted such pressure against the relatively low walls left standing that they were in danger of being toppled (fig. 30a), or where the debris of one building had piled up against another structure (fig. 30b)

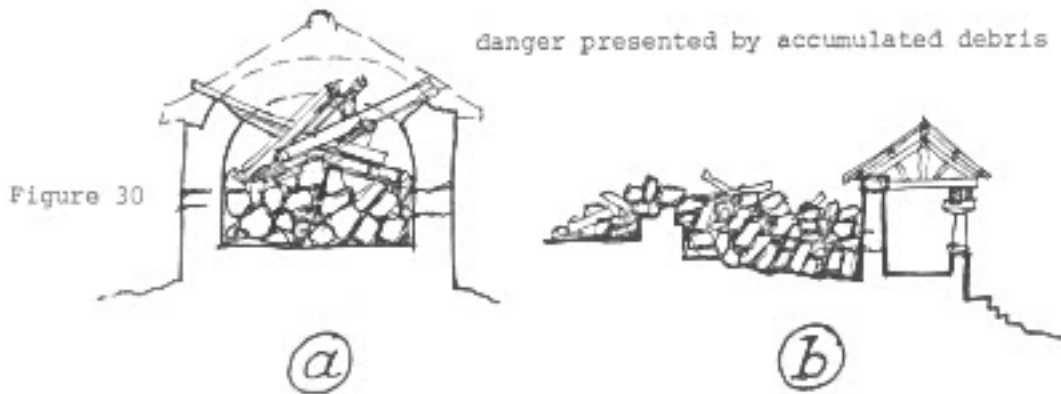

As a general rule, however, in the interests of workers' safety, no removal of debris should be allowed until the stability of all large masonry features still standing has been improved (photo 22).

In all cases, the debris are sorted as it is removed. Space should be set aside for the storage of each category: rubble, rough stone, whole bricks, dressed stone, reusable roofing materials, beams, joists and structural timbers, joinery (doors, windows, staircases, etc.), valuable small items (for example bits of plaster with mural painting which it may be thought possible to reassemble later on), hardware, art objects and collectors' items to be evacuated to movable property conservation centres (fig. 31).

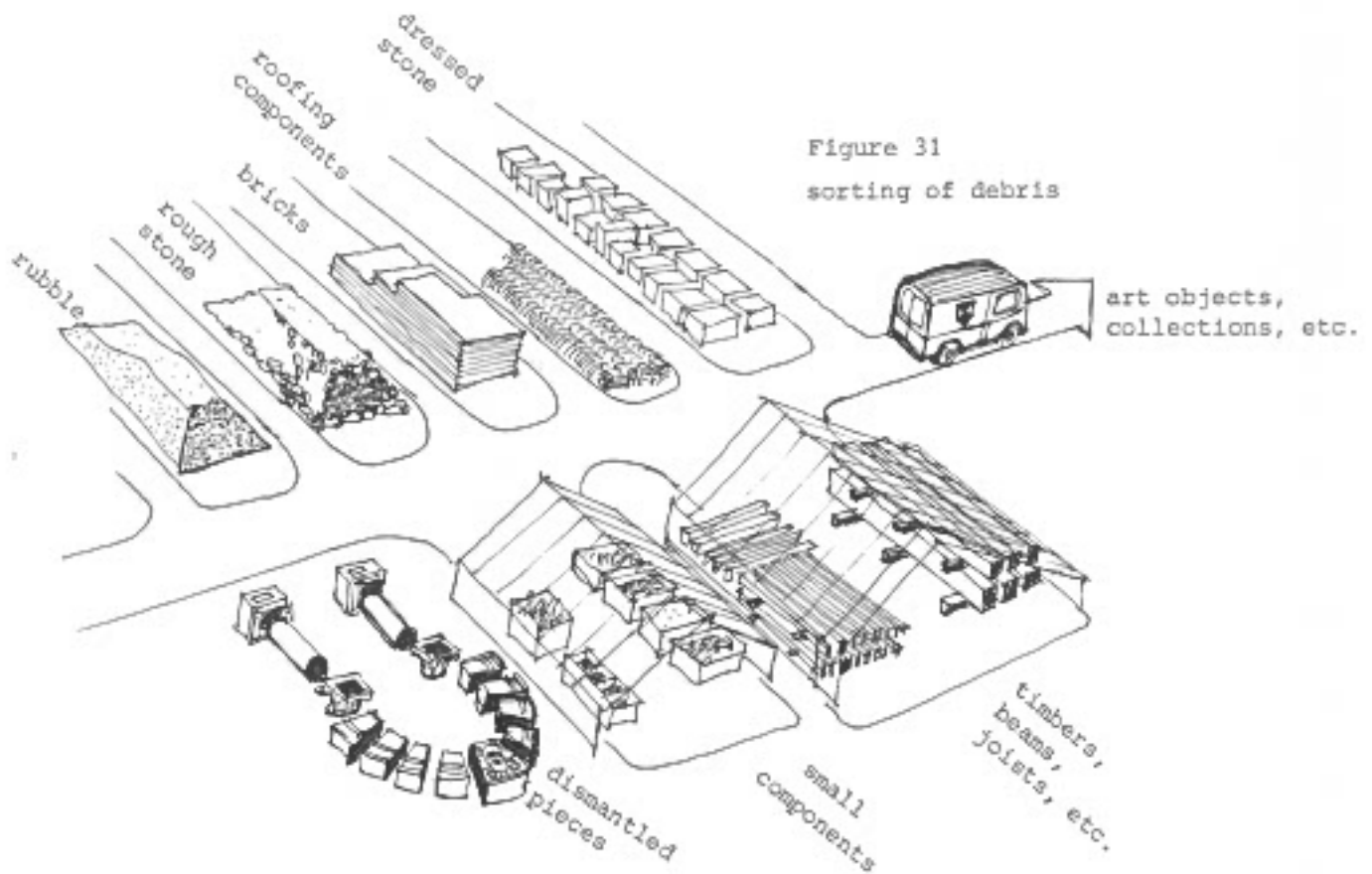

be short and efficient.¹ Arrangements for co-ordinating the assistance available from these organizations should be worked out by the Service in order to avoid duplication of effort.

These organizations can be asked:

to send experts and specialists to perform specific tasks (damage assessment, application of safeguards, preservation of movable property, preparation of restoration projects, photogrammetric surveys, etc.);

to send equipment or material which is in short supply in the country (vehicles, site equipment, scaffolding components, photographic equipment or supplies, preservation material, etc.).

In practice, because the purchase and transport of equipment are bound to take time, international assistance will be particularly valuable in the next stage, i.e. in the final consolidation of structures, the restoration of monuments, the preservation of movable property, etc., all of which are highly specialized and extremely delicate operations in an earthquake zone. International assistance can be of use in making advance preparations for this second phase by sending personnel abroad on special training fellowships (earthquake engineering, preservation of monuments and art objects, preservation of mural paintings, architectural photogrammetry, etc.). On their return these fellows will become officials of the Service and take charge of restoring the cultural heritage in the disaster area.

10. Preventive measures

Although, in the present state of seismological research, earthquakes cannot - with few exceptions - be forecast, we do at least know the exact zones where they may occur. It is possible, in these zones, to prepare for the eventuality of an earthquake and to take measures accordingly in order to be better equipped to cope with disaster.

(a) Evaluating the earthquake threat

The world's earthquake zones are fairly accurately known. They correspond to the edges of the great tectonic plates that support the continents and oceans (fig. 32). Moreover earthquake maps are published in every country and periodically revised, supplemented and refined. Owing to the compartmentalization of disciplines and institutions, however, these maps are not, as a rule, distributed widely enough and in most cases are unknown, for example, to those responsible for the preservation of monuments.

These maps show several zones which are differentiated by degree of expected hazard as measured by various parameters: maximum intensities historically observed, maximum intensities foreseeable, maximum accelerations foreseeable, etc. They may be supplemented by the maps of so-called seismic microzones which are now beginning to be published on certain towns or areas; these take into account the local behaviour of the subsoil which may weaken or amplify the effects of a particular earthquake, and thus provide the basis for a very exact appreciation of the earthquake threat at a particular point: for example to a monument.

1. All too often the Service is obliged to take the representative of each organization on a tour of many monuments all over the disaster area, keeping a motor vehicle, a driver and staff busy for several days. It would be more economical merely to show him a few representative cases and provide him with a well-prepared file (photographs, map, plans of monuments, description of damage) covering the whole area.

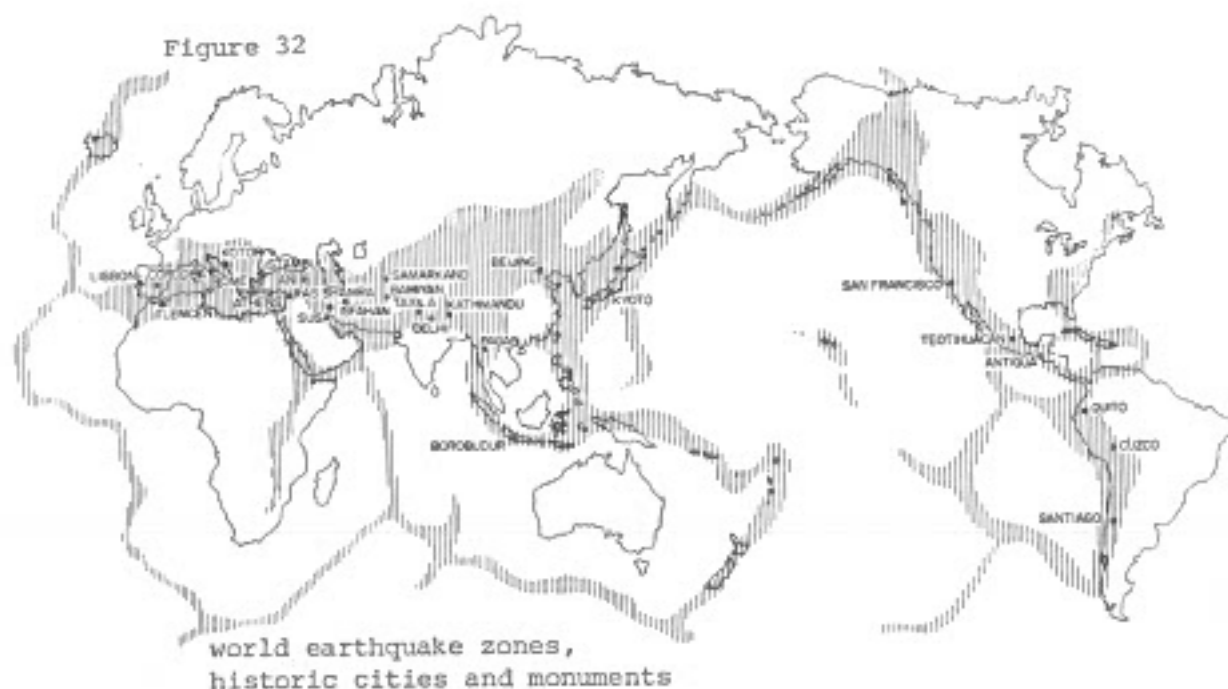

The degree of progress made in the seismological and geotechnical research necessary for these studies varies from country to country, but there is at least a national map available everywhere. It is therefore recommended that, in every country, the national Service for protection of the cultural heritage should ask the responsible organization for a copy of the latest seismicity map and pinpoint on it the protected historic monuments, the old cities and quarters, the archaeological sites and the country's main museums and libraries. This will provide a clear picture of the most threatened sites and of the priorities to be observed.

The information thus compiled should be passed on to the competent Service in each area, with a copy of the seismic map indicating the position of each monument in relation to the various earthquake zones.

(b) Emergency plans

Sometimes the civil and military authorities in earthquake areas have occasionally prepared emergency plans, to take effect as soon as disaster strikes; these plans embody several scenarios taking into account local conditions, the distribution of essential tasks and the co-ordination of relief activities. In principle such plans are reviewed and improved from time to time. Those in charge of the Service at both the national and the regional level should ask to see these plans, make their comments and participate in their revision - or, even better, in their preparation - so as to ensure that protection of the cultural heritage is included.

(c) Documentation

After an earthquake, a precise knowledge of every monument is one of the most crucial factors in making an accurate assessment of the damage and the safeguards required. Moreover detailed documentation showing the form and condition the monument was in before the earthquake is essential to its eventual repair, restoration and preservation.

It is necessary to assemble the following items relating to each monument:

a precise graphic record, on a scale suited to the dimensions of the monument (at least 1:50, with detailed drawings at 1:20, or 1:10), comprising the plan of the different levels and all necessary elevations and sections;

the technical file on all repair, maintenance and conversion work;

a comprehensive set of black-and-white and colour photographs (general views and close-ups of the outside and inside);

complete and accurate inventories of the movable property which the monument contains (art objects, collections, furniture, books, etc.);

bibliographical references and documentation on the history of the monument from its erection to the present day.

Several copies of these documents, including some on microfilm, should be kept and deposited in several known, supervised places and on the safest possible premises. The original documents in particular (photographic negatives, original drawings, etc.) should be kept in a building constructed to the strictest seismic zones.

When a country undertakes a photogrammetric survey of its monuments, the choice of the monuments to be covered and the order of priority between them should be based primarily on the relative seismicity of the area in which they are situated. Such monuments may be seriously damaged or destroyed at any moment, and the possibility of consulting a photogrammetric survey made before the disaster would afford the best chance of successful restoration. Systematic photogrammetry campaigns should be organized to cover the monuments in all earthquake zones, with facilities for filing the exposure pairs in a safe building (or, even better, for making duplicates) and plotting only as need arises.

This documentation may be assembled at the national, regional or local level. In any case it is desirable that the Service should have, at each of its local offices, a copy of the plans of the monuments for which it is responsible and a set of photographic prints.

During the emergency, what the Service needs most is to have simplified plans of every monument, for use in noting the damage (see chapter 5 and fig. 17) and in calculating requirements of equipment and materials (area of covering, length and height of scaffolding, length of straps, etc.). These simplified but accurate drawings should be on a small scale for ease of handling in the field (exceptional cases apart, the various drawings of a monument should fit on to a standard 210 x 297 mm sheet which can be easily photocopied). They will be prepared by the Service and kept in two or three copies in carefully selected places; they will be accurately filed (in each district, by localities, in alphabetical or numerical order) so that the file on each monument can be retrieved quickly and correctly.

4. Motor fuel. Supplies of motor fuel may also be cut off for several days. It is therefore advisable to keep a small reserve stock of fuel for vehicles and the generator (one or two 200-litre barrels of petrol and, if necessary, diesel oil) in a place which is isolated (an independent shelter) but proof against theft. A small hand-pump, or at least a flexible tube, should be kept in the same place to fill the fuel-tanks.

5. Advance preparations. Little in the way of direct preparations can be made in advance. It is, of course, simple enough to print damage assessment forms, to have a reserve stock of angle plates made and to buy steel rods for strapping, but what are the chances of finding these items quickly and in good condition if an earthquake occurs fifty or 100 years later? Such preparations are probably better organized on a national scale: e.g. the printing of stickers for marking monuments, which may be sent to each local or regional Service and replaced every ten years (with the advantage of reminding officials of the earthquake threat); the printing of various forms and the stocking of materials and other items that can be sent to the disaster area as soon as an earthquake is reported.

At local Service level, rather than keep a stock of material lying idle which may be found at any time to have become unusable, or which may be ruined by the earthquake, it makes better sense to have supplies delivered regularly so that there is always enough in stock for the critical period. For example, in addition to the items mentioned above (paras. 2, 3 and 4), films, paper and photographic supplies, batteries for the torches and appliances (calculators, cameras, etc.), office supplies and drawing materials should be continuously available. But it would be a mistake to keep these supplies in a cupboard marked 'Open only in case of earthquake'

The stock should be turned over regularly so that products such as films and sensitized paper do not become outdated. About one year's normal supply should be kept in stock; this may be used up in two or three weeks if an earthquake occurs.

(e) Upkeep of monuments. Lastly it should be emphasized that the state of preservation of monuments is of crucial importance in the event of an earthquake. It has been seen above (chapter 5) that earthquakes cause masonry to break up its lines of least resistance. Certain weak points, such as the openings, are an integral part of the monument and cannot be eliminated; but any accidental weakness in a building, such as a poor bond between walls (whether they were erected simultaneously or not), setting of the foundations, cracks, timber connections in poor condition, etc., is a factor in worsening the damage.

Regular and correct maintenance of monuments by the accepted methods of good preservation practice is even more important in earthquake areas than elsewhere. Experience gained in several earthquakes has shown that masonry properly repaired and maintained, even without precautionary strapping or reinforcement, has resisted with a minimum of damage and sometimes without any damage, whereas in the immediate vicinity buildings that were poorly maintained or not maintained at all were dislocated or collapsed. The vital importance of good upkeep means first and foremost that all monuments should be periodically inspected; any weakness should be noted immediately and remedied as soon as possible.

The methods of repairing slight defects are in no way different from the usual rules for the preservation of monuments. Naturally, where old masonry is to be repaired, the use of cement mortar, which is too rigid and brittle, should be avoided; it is better to use lime mortar in order to obtain the greatest possible homogeneity in the building repaired.

Nevertheless, in earthquake areas even more than elsewhere, the work should be carried out with great care, for the slightest carelessness can be very dangerous. Even everyday conversion and development work must be done with caution. It was observed after the Friuli earthquake (Italy, 1976) that routine modernization work on old houses had had serious consequences. In the process of laying water pipes and electric cables in rough stone walls to serve newly converted bathrooms, wide hollows had been created because it was easier to remove a whole stone than to scoop out a channel. These hollows, filled in with different materials and different mortar, became heterogeneous lines in the masonry, along which the walls ruptured during the earthquake. Thus a structural weakening worsened the damage.

In cases of serious defects requiring large-scale repair or consolidation work, the situation of the monument in an earthquake zone should be taken into account in considering the methods to be used. In such cases, it should always be possible to consult an earthquake engineering specialist and to treat the repair work as an opportunity to improve the overall earthquake resistance of the structure. Where complex monuments are concerned, this is a highly specialized task for which architects and engineers are generally ill-prepared. The operation should include a vulnerability study, a geotectonic survey of the area, a geotechnical analysis of the foundation soil, a dynamic analysis of the structure and a study of its foreseeable behaviour according to various seismic parameters.

PLAN OF OPERATIONS

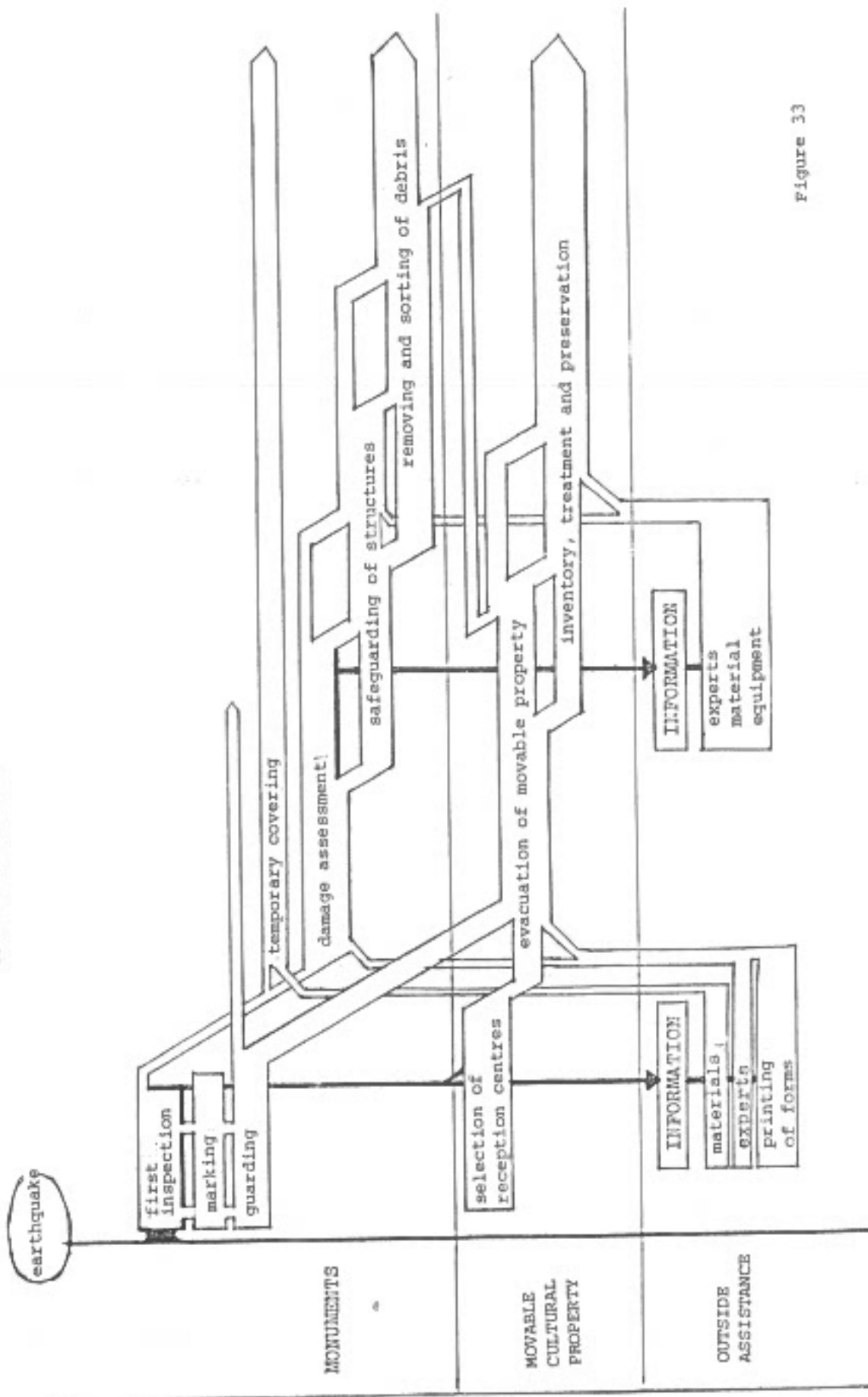









Figure 33

Damage Assessment Form
A. IMMOVABLE CULTURAL PROPERTY

INVENTORY OF DAMAGE		REFERENCE No.																																																																																																						
1	NAME OF MONUMENT																																																																																																							
2	ARCHAEOLOGICAL SITE <input type="radio"/> URBAN GROUP OF BUILDINGS <input type="radio"/> FORTIFIED URBAN AREA <input type="radio"/> MONASTERY/MONASTERIES <input type="radio"/> RURAL GROUP OF BUILDINGS <input type="radio"/> ISOLATED MONUMENT <input type="radio"/>																																																																																																							
	<table border="1"> <tr> <td rowspan="10" style="writing-mode: vertical-rl; transform: rotate(180deg);">antiquity</td> <td></td> <td colspan="10">century</td> </tr> <tr> <td></td> <td>12</td><td>13</td><td>14</td><td>15</td><td>16</td><td>17</td><td>18</td><td>19</td><td>20</td> </tr> <tr> <td>religious monument</td> <td></td><td></td><td></td><td></td><td></td><td></td><td></td><td></td><td></td> </tr> <tr> <td>habitation</td> <td></td><td></td><td></td><td></td><td></td><td></td><td></td><td></td><td></td> </tr> <tr> <td>public building</td> <td></td><td></td><td></td><td></td><td></td><td></td><td></td><td></td><td></td> </tr> <tr> <td>building serving an economic purpose</td> <td></td><td></td><td></td><td></td><td></td><td></td><td></td><td></td><td></td> </tr> <tr> <td>military architecture (fortified)</td> <td></td><td></td><td></td><td></td><td></td><td></td><td></td><td></td><td></td> </tr> <tr> <td>ethnological structure</td> <td></td><td></td><td></td><td></td><td></td><td></td><td></td><td></td><td></td> </tr> <tr> <td>building serving a technical purpose</td> <td></td><td></td><td></td><td></td><td></td><td></td><td></td><td></td><td></td> </tr> <tr> <td>monument to the struggle for national liberation</td> <td></td><td></td><td></td><td></td><td></td><td></td><td></td><td></td><td></td> </tr> </table>	antiquity		century											12	13	14	15	16	17	18	19	20	religious monument										habitation										public building										building serving an economic purpose										military architecture (fortified)										ethnological structure										building serving a technical purpose										monument to the struggle for national liberation										
antiquity			century																																																																																																					
			12	13	14	15	16	17	18	19	20																																																																																													
	religious monument																																																																																																							
	habitation																																																																																																							
	public building																																																																																																							
	building serving an economic purpose																																																																																																							
	military architecture (fortified)																																																																																																							
	ethnological structure																																																																																																							
	building serving a technical purpose																																																																																																							
	monument to the struggle for national liberation																																																																																																							
3	<table border="1"> <tr> <td rowspan="6" style="writing-mode: vertical-rl; transform: rotate(180deg);">LOCATION</td> <td>commune _____</td> <td rowspan="6" style="writing-mode: vertical-rl; transform: rotate(180deg);">OVERALL FLOOR SPACE</td> <td>basement _____</td> <td rowspan="6" style="writing-mode: vertical-rl; transform: rotate(180deg);"> H² B² J² N² </td> </tr> <tr> <td>place _____</td> <td>ground floor _____</td> </tr> <tr> <td>town _____</td> <td>1 _____</td> </tr> <tr> <td>address _____</td> <td>2 _____</td> </tr> <tr> <td>land register No. _____</td> <td>3 _____</td> </tr> <tr> <td>owner _____</td> <td>4 _____</td> </tr> <tr> <td colspan="2"> CONDITION BEFORE EARTHQUAKE <input type="radio"/> good <input type="radio"/> medium <input type="radio"/> poor </td> <td>TOTAL _____</td> <td>H²</td> </tr> <tr> <td colspan="2"> CATEGORY OF MONUMENT _____ PROTECTION REGIME _____ </td> <td></td> <td></td> </tr> </table>	LOCATION	commune _____	OVERALL FLOOR SPACE	basement _____	H ² B ² J ² N ²	place _____	ground floor _____	town _____	1 _____	address _____	2 _____	land register No. _____	3 _____	owner _____	4 _____	CONDITION BEFORE EARTHQUAKE <input type="radio"/> good <input type="radio"/> medium <input type="radio"/> poor		TOTAL _____	H ²	CATEGORY OF MONUMENT _____ PROTECTION REGIME _____																																																																																			
LOCATION	commune _____		OVERALL FLOOR SPACE		basement _____		H ² B ² J ² N ²																																																																																																	
	place _____				ground floor _____																																																																																																			
	town _____				1 _____																																																																																																			
	address _____				2 _____																																																																																																			
	land register No. _____				3 _____																																																																																																			
	owner _____	4 _____																																																																																																						
CONDITION BEFORE EARTHQUAKE <input type="radio"/> good <input type="radio"/> medium <input type="radio"/> poor		TOTAL _____	H ²																																																																																																					
CATEGORY OF MONUMENT _____ PROTECTION REGIME _____																																																																																																								
4	DAMAGE CAUSED BY THE EARTHQUAKE	destroyed	heavily damaged	damaged	slightly damaged	intact																																																																																																		
	chimney(s) _____	<input type="radio"/>	<input type="radio"/>	<input type="radio"/>	<input type="radio"/>	<input type="radio"/>																																																																																																		
	covering _____	<input type="radio"/>	<input type="radio"/>	<input type="radio"/>	<input type="radio"/>	<input type="radio"/>																																																																																																		
	structure _____	<input type="radio"/>	<input type="radio"/>	<input type="radio"/>	<input type="radio"/>	<input type="radio"/>																																																																																																		
	dome(s) _____	<input type="radio"/>	<input type="radio"/>	<input type="radio"/>	<input type="radio"/>	<input type="radio"/>																																																																																																		
	vault(s) _____	<input type="radio"/>	<input type="radio"/>	<input type="radio"/>	<input type="radio"/>	<input type="radio"/>																																																																																																		
	ceiling(s) _____	<input type="radio"/>	<input type="radio"/>	<input type="radio"/>	<input type="radio"/>	<input type="radio"/>																																																																																																		
	wooden floor structure(s) _____	<input type="radio"/>	<input type="radio"/>	<input type="radio"/>	<input type="radio"/>	<input type="radio"/>																																																																																																		
	other floor(s) _____	<input type="radio"/>	<input type="radio"/>	<input type="radio"/>	<input type="radio"/>	<input type="radio"/>																																																																																																		
	bearing wall(s) _____	<input type="radio"/>	<input type="radio"/>	<input type="radio"/>	<input type="radio"/>	<input type="radio"/>																																																																																																		
	non-bearing wall(s) _____	<input type="radio"/>	<input type="radio"/>	<input type="radio"/>	<input type="radio"/>	<input type="radio"/>																																																																																																		
	arch(es) _____	<input type="radio"/>	<input type="radio"/>	<input type="radio"/>	<input type="radio"/>	<input type="radio"/>																																																																																																		
	columns _____	<input type="radio"/>	<input type="radio"/>	<input type="radio"/>	<input type="radio"/>	<input type="radio"/>																																																																																																		
	staircase(s) _____	<input type="radio"/>	<input type="radio"/>	<input type="radio"/>	<input type="radio"/>	<input type="radio"/>																																																																																																		
	foundations _____	<input type="radio"/>	<input type="radio"/>	<input type="radio"/>	<input type="radio"/>	<input type="radio"/>																																																																																																		
	belfry/belfries _____	<input type="radio"/>	<input type="radio"/>	<input type="radio"/>	<input type="radio"/>	<input type="radio"/>																																																																																																		
	minaret(s) _____	<input type="radio"/>	<input type="radio"/>	<input type="radio"/>	<input type="radio"/>	<input type="radio"/>																																																																																																		
	architectural decoration _____	<input type="radio"/>	<input type="radio"/>	<input type="radio"/>	<input type="radio"/>	<input type="radio"/>																																																																																																		
	iconostasis _____	<input type="radio"/>	<input type="radio"/>	<input type="radio"/>	<input type="radio"/>	<input type="radio"/>																																																																																																		
	mural painting(s) _____	<input type="radio"/>	<input type="radio"/>	<input type="radio"/>	<input type="radio"/>	<input type="radio"/>																																																																																																		

5	DEGREE OF DANGER <input type="radio"/> repair feasible <input type="radio"/> repair impossible	STATUS OF THE MONUMENT <input type="radio"/> unchanged <input type="radio"/> changed <input type="radio"/> not retained	EMERGENCY ACTION <input type="radio"/>
6	OUTLINE PLAN (AT GROUND LEVEL) OF THE MONUMENT AND PRINCIPAL DIMENSIONS. PHOTOGRAPHS AND INDICATION OF DAMAGE (whole of second page)		
7	STRUCTURAL CHARACTERISTICS (type and quality of building materials and bonding components)		
8	DESCRIPTION OF DEFORMATIONS AND STRUCTURAL DAMAGE		
9	EMERGENCY ACTION PROPOSED <input type="checkbox"/> total demolition <input type="checkbox"/> partial demolition <input type="checkbox"/> temporary covering <input type="checkbox"/> shoring <input type="checkbox"/> external scaffolding <input type="checkbox"/> internal scaffolding <input type="checkbox"/> protection of mural paintings <input type="checkbox"/> protection of architectural decoration <input type="checkbox"/> _____ <input type="checkbox"/> _____		
10	REPAIR PROGRAMME PROPOSED <input type="checkbox"/> demolition(s) <input type="checkbox"/> chimney(s) <input type="checkbox"/> covering <input type="checkbox"/> timber structure <input type="checkbox"/> dome(s) <input type="checkbox"/> vault(s) <input type="checkbox"/> ceiling(s) <input type="checkbox"/> wooden floor(s) <input type="checkbox"/> other floor(s) <input type="checkbox"/> bearing wall(s) <input type="checkbox"/> non-bearing wall(s) <input type="checkbox"/> arch(es) <input type="checkbox"/> columns <input type="checkbox"/> piers <input type="checkbox"/> beam(s) <input type="checkbox"/> staircase(s) <input type="checkbox"/> geomechanical exploration <input type="checkbox"/> foundation(s) <input type="checkbox"/> belfry/belfries, minaret(s) <input type="checkbox"/> external plastering <input type="checkbox"/> internal plastering <input type="checkbox"/> preservation <input type="checkbox"/> restoration <input type="checkbox"/> _____ <input type="checkbox"/> _____		

5	<p>DEGREE OF DANGER</p> <p><input type="checkbox"/> repair feasible <input type="checkbox"/> repair impossible</p>	<p>STATUS OF THE MONUMENT</p> <p><input type="checkbox"/> unchanged <input type="checkbox"/> changed <input type="checkbox"/> not retained</p>	<p>EMERGENCY ACTION</p> <p><input checked="" type="checkbox"/></p>
6	<p>OUTLINE PLAN (AT GROUND LEVEL) OF THE MONUMENT AND PRINCIPAL DIMENSIONS. PHOTOGRAPHS AND INDICATION OF DAMAGE</p> <p>(whole of second page)</p>		
7	<p>STRUCTURAL CHARACTERISTICS (type and quality of building materials and bonding components)</p>		
8	<p>DESCRIPTION OF DEFORMATIONS AND STRUCTURAL DAMAGE</p>		
9	<p>EMERGENCY ACTION PROPOSED</p> <p>total demolition _____ <input type="checkbox"/></p> <p>partial demolition _____ <input type="checkbox"/></p> <p>temporary covering _____ <input type="checkbox"/></p> <p>shoring _____ <input type="checkbox"/></p> <p>external scaffolding _____ <input type="checkbox"/></p> <p>internal scaffolding _____ <input type="checkbox"/></p> <p>protection of mural paintings _____ <input type="checkbox"/></p> <p>protection of architectural decoration _____ <input type="checkbox"/></p> <p>_____ <input type="checkbox"/></p> <p>_____ <input type="checkbox"/></p>		
10	<p>REPAIR PROGRAMME PROPOSED</p> <p>demolition(s) _____ <input type="checkbox"/></p> <p>chimney(s) _____ <input type="checkbox"/></p> <p>covering _____ <input type="checkbox"/></p> <p>timber structure _____ <input type="checkbox"/></p> <p>dome(s) _____ <input type="checkbox"/></p> <p>vault(s) _____ <input type="checkbox"/></p> <p>ceiling(s) _____ <input type="checkbox"/></p> <p>wooden floor(s) _____ <input type="checkbox"/></p> <p>other floor(s) _____ <input type="checkbox"/></p> <p>bearing wall(s) _____ <input type="checkbox"/></p> <p>non-bearing wall(s) _____ <input type="checkbox"/></p> <p>arch(es) _____ <input type="checkbox"/></p> <p>columns _____ <input type="checkbox"/></p> <p>piers _____ <input type="checkbox"/></p> <p>beam(s) _____ <input type="checkbox"/></p> <p>staircase(s) _____ <input type="checkbox"/></p> <p>geomechanical exploration _____ <input type="checkbox"/></p> <p>foundation(s) _____ <input type="checkbox"/></p> <p>belfry/belfries, minaret(s) _____ <input type="checkbox"/></p> <p>external plastering _____ <input type="checkbox"/></p> <p>internal plastering _____ <input type="checkbox"/></p> <p>preservation _____ <input type="checkbox"/></p> <p>restoration _____ <input type="checkbox"/></p> <p>_____ <input type="checkbox"/></p> <p>_____ <input type="checkbox"/></p> <p>_____ <input type="checkbox"/></p>		

11	<p>DAMAGE CLASSIFICATION AND STATE OF SERVICEABILITY OF THE BUILDING</p> <p>I / <u>SERVICEABLE</u> (green category)</p> <p>IA - class 1  O intact except superficial damage _____</p> <p>IIB - class 2  O no structural damage _____</p> <p>II / <u>TEMPORARILY UNSERVICEABLE</u> (yellow category)</p> <p>IIA - class 1  O structural damage _____</p> <p>IIB - class 2  O heavy structural damage _____</p> <p>III / <u>UNSERVICEABLE</u> (red category)</p> <p>IIIA - class 1  O very heavy structural damage _____</p> <p>IIIB - class 2  O partial or total destruction _____</p> <p>(The damage classification and state of serviceability of buildings have been established in accordance with the criteria applied by the Technical Commission for Damage Assessment in the Socialist Republic of Montenegro.)</p>
12	<p>ESTIMATED COST OF REPAIR</p> <p>1. value of the building before the earthquake: _____ m² x _____ dinars = _____ dinars.</p> <p>2. cost of restoring the building to its pre-earthquake condition (structural repair): _____ m² x _____ dinars = _____ dinars.</p> <p>3. total cost of repair (consolidation): _____ m² x _____ dinars = _____ dinars.</p>
13	NOTES
14	<p>The members of the Commission _____</p> <p>_____</p> <p>Photographic coverage: No. of negatives _____ photographer _____ copyright owner _____</p> <p>place and date: _____</p>

Damage Assessment Form
B. MOVABLE CULTURAL PROPERTY

INVENTORY OF DAMAGE				REFERENCE No.									
1	NAME OF OBJECT	antiquity											
2	NATURE OF OBJECT												
	religious												
	profane												
	ethnological												
	archaeological												
	literary/archives												
	technical												
	object in the struggle for national liberation												
3	MATERIAL												
	metal												
	wood												
	fabric/textile												
	leather												
	paper												
	pottery												
	glass												
	porcelain												
	stone												
	bone												
	horn												
	parchment												
	precious stones												
4	location	commune _____ place _____ town _____ address _____ owner _____											
CONDITION BEFORE EARTHQUAKE													
<input type="radio"/> good <input type="radio"/> medium <input type="radio"/> poor													
CLASSIFICATION CATEGORY _____				destroyed heavily damaged damaged slightly damaged intact									
PROTECTION REGIME _____													
5	DAMAGE CAUSED BY THE EARTHQUAKE			<input type="radio"/> destroyed <input type="radio"/> heavily damaged <input type="radio"/> damaged <input type="radio"/> slightly damaged <input type="radio"/> intact									
6	DEGREE OF DANGER			STATUS OF THE OBJECT				EMERGENCY ACTION					
<input type="radio"/> repair feasible <input type="radio"/> repair impossible			<input type="radio"/> unchanged <input type="radio"/> changed <input type="radio"/> not retained				<input type="radio"/>						

7	DRAWING OF THE OBJECT AND PRINCIPAL DIMENSIONS. PHOTOGRAPHS AND INDICATION OF DAMAGE (whole of second page)
8	PRINCIPAL CHARACTERISTICS OF THE OBJECT
9	DESCRIPTION OF DEFORMATIONS AND DAMAGE
10	<p>EMERGENCY ACTION PROPOSED</p> <p>cleaning _____ <input type="radio"/></p> <p>dismantling _____ <input type="radio"/></p> <p>packing _____ <input type="radio"/></p> <p>transport _____ <input type="radio"/></p> <p>disinfection _____ <input type="radio"/></p> <p>storage _____ <input type="radio"/></p> <p>drying _____ <input type="radio"/></p> <p>inventory _____ <input type="radio"/></p> <p>photographs _____ <input type="radio"/></p>
11	<p>REPAIR PROGRAMME PROPOSED</p> <p>total preservation _____ <input type="radio"/></p> <p>preservation with reconstitution _____ <input type="radio"/></p> <p>preservation with restoration _____ <input type="radio"/></p>

12	<p>DAMAGE CLASSIFICATION AND STATE OF SERVICEABILITY OF THE OBJECT</p> <p><input type="radio"/> serviceable <input type="radio"/> temporarily unserviceable <input type="radio"/> unserviceable</p>
13	<p>ESTIMATED COST OF REPAIR</p> <p>cost of restoring the object to its previous condition</p> <p style="text-align: right;">_____ dinars.</p>
14	<p>NOTES</p>
15	<p>The members of the Commission: _____ _____</p> <p>Photographic coverage: No. of negatives _____ photographer _____ copyright owner _____</p> <p>place and date _____</p>



Photo 1

Friuli (northern Italy). Systematic demolition of ancient houses in a village damaged by the earthquake of 6 May 1976.

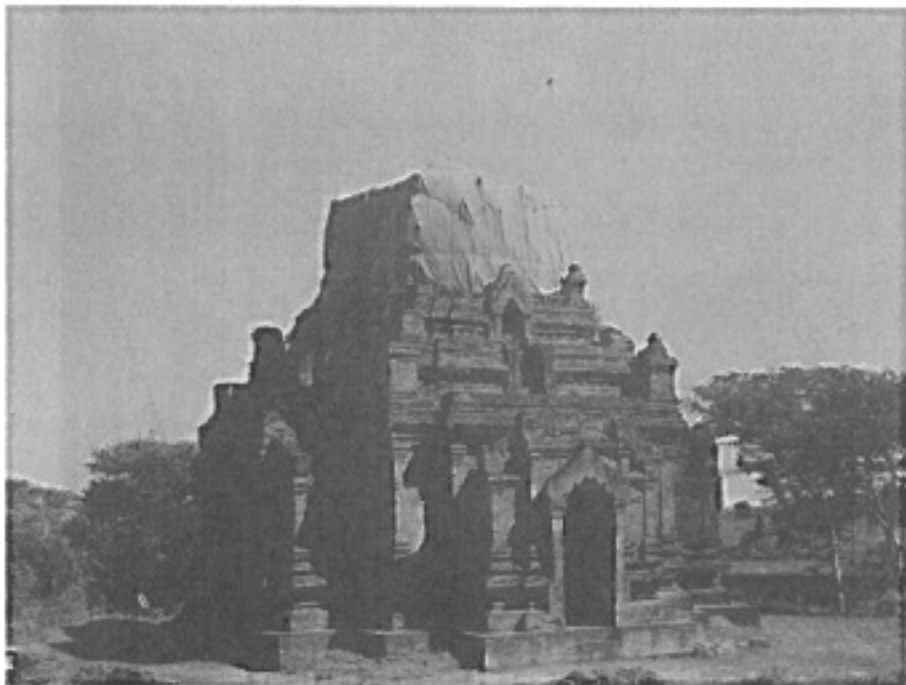

Photo 2

Pagan (Burma). Tarpaulin used as temporary covering for roof of Ngamyethna temple No. 1831, damaged by the earthquake of 8 July 1975.



Photo 3

Podlastva monastery, interior of the church and frescoes on apse wall under temporary roofing.



Photo 4

Gradiste monastery (Montenegro), church of St Nicholas: part-collapse of vault, dangerously exposing frescoes of 1620 AD.



Photo 5

Gradiste monastery: temporary protective roofing.



Photo 6

Antigua Guatemala: cathedral damaged by the earthquakes of July 1773 and 4 February 1976. Diagonal x-shaped cracks evidencing lengthwise oscillation of wall.

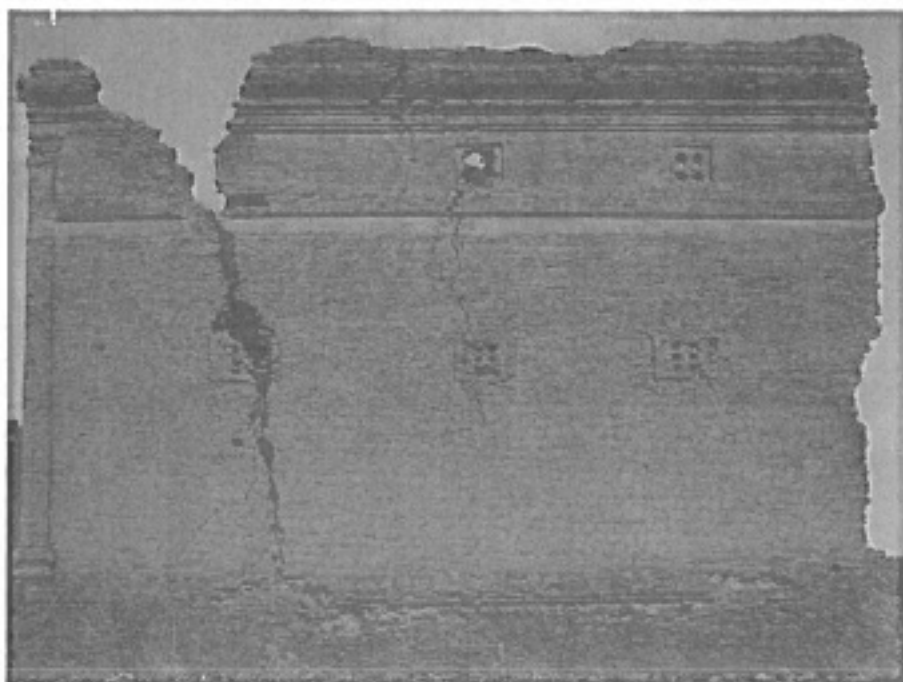

Photo 7

Pagan, monastery No. 223. West wall, split on the left by a crack that follows the windows from floor to floor. On the right, the corner of the building has collapsed along with the entire south wall. In the centre, a vertical crack linking the openings.



Photo 8

Pagan, temple No. 1828. West wall split into three. Crushing of the base and subsidence of the foundations evidenced by the tilt of the south wall (on the right) and of the central fragment.



Photo 9

Brajici (Montenegro): Dislocation of the walls of a house by cracks that follow the openings.

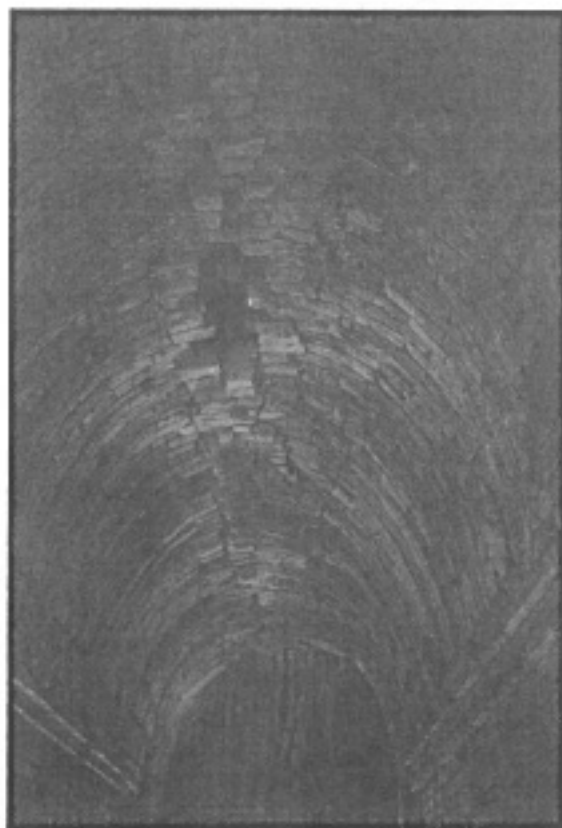

Photo 10

Pagan, monastery No. 239: vault cracked and deformed, with fall of several bricks.

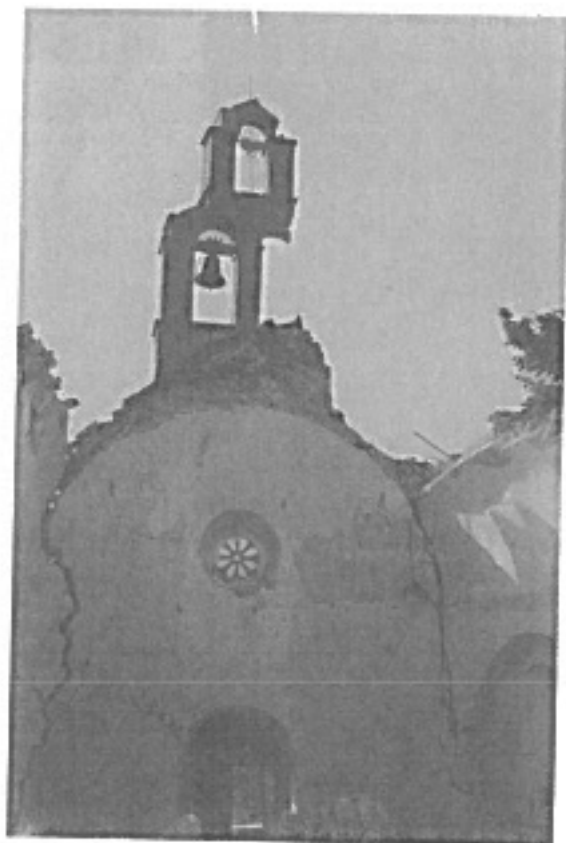

Photo 11

Brajici (Montenegro): the entire vault of the church has collapsed. At the apex of the front façade, a part of the bell gable (campanile a vela) has stayed in place - an unstable decorative component which is difficult to protect. It will be better to dismantle this and place it in shelter until the monument as a whole is being restored.

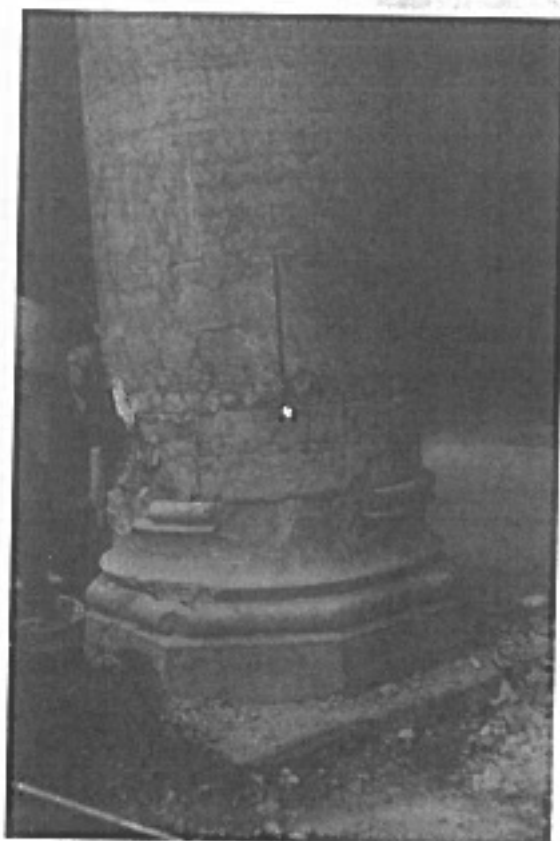

Photo 12

Gemona (Friuli): a column in the cathedral, tilted with crushing of the bottom courses.

Photo 13

Gemona (Friuli): façade of the church of the Madonna di Fossale, cleft by a wide gap that follows the openings and dislocated by diagonal cracks towards the corners.



Photo 14

Marking of a monument damaged by the earthquake of 15 April 1979 (Montenegro) by two different organizations:

Left, the blue emblem of the Hague Convention, affixed by the Service, identifies the building as a protected historic monument.

Right, the figures indicate the file number of the building with the Technical Commission for Damage Assessment: yellow figures double-underlined (16/2), which indicate classification in category IIB (temporarily unserviceable; heavy structural damage). The new marking below, added after the aftershock of 24 May 1979, indicates: category IIIA, not reusable, structural dislocation.



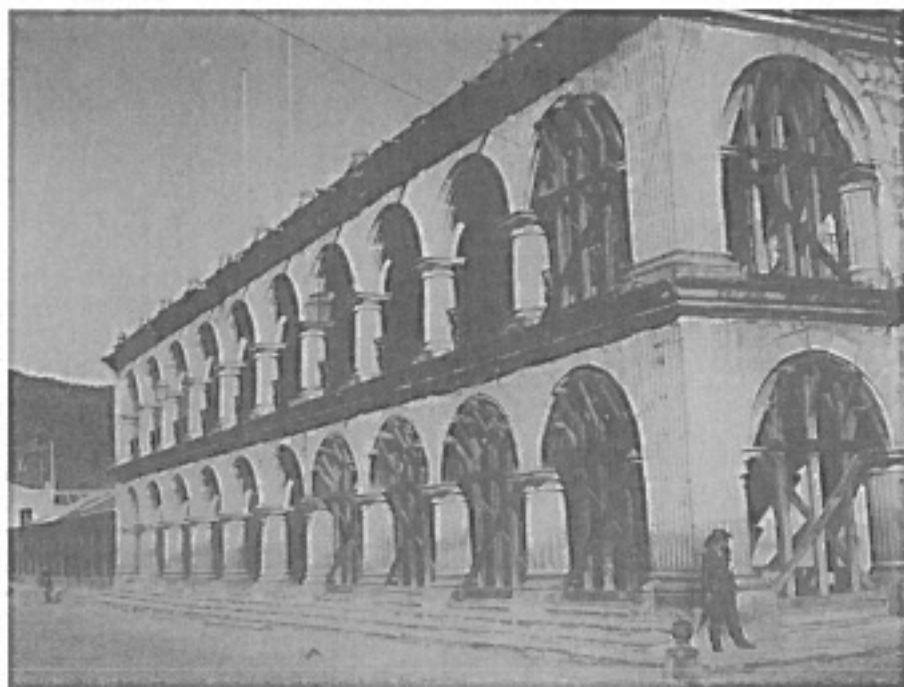

Photo 15

Antigua Guatemala, Palacio del Ayuntamiento: bracing of openings near the corner of the monument. But this measure should be supplemented by fitting straps and ties if it is to be effective in an aftershock.



Photo 16

Gemona (Friuli): to the left, bracing of arches and temporary covering on town hall. To the right, the arcades of the houses have been bricked up.



Photo 19

Gemona (Friuli), Palazzo Gurigatti:
same view after the aftershock of 15 September 1976.
The monument has fallen in on itself completely,
behind the props. The neighbouring buildings are
partly destroyed.



Photo 20

Antigua Guatemala, cathedral:
shoring of a single pillar in the ruins left by
the earthquakes of 1773 and 1976.

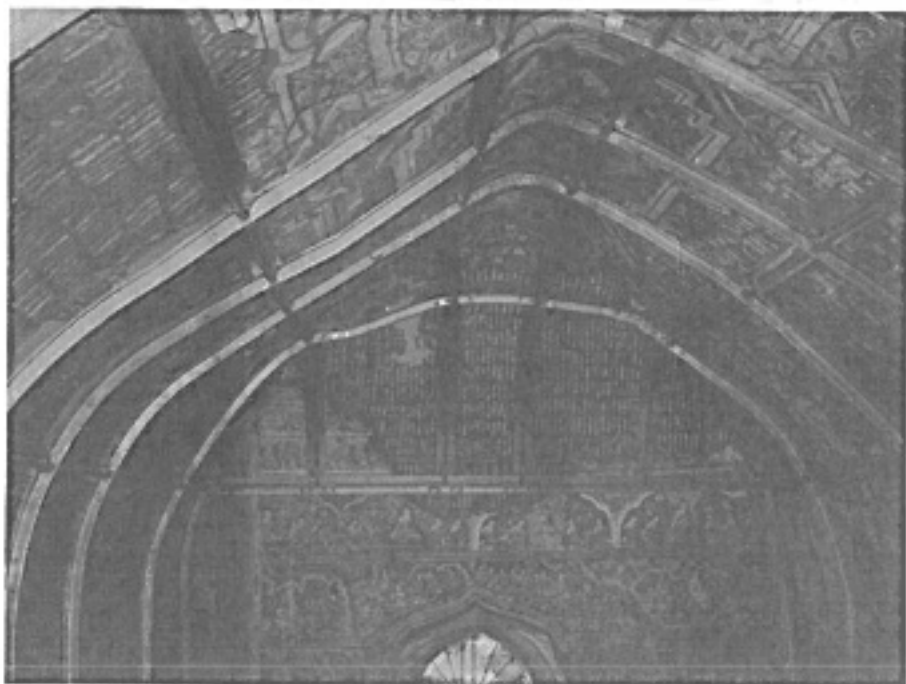

Photo 21

Pagan, Upali Thein (No. 2121): The brickwork vault, plastered and painted in the intrados (paintings of the eighteenth century AD), was severely deformed by the 1975 earthquake. A supporting framework of metal arches has been installed pending general reinforcement of the structure.



Photo 22

Venzona (Friuli): Debris of old houses destroyed around the town hall, which was severely damaged.



Photo 23

Budva (Montenegro): The ramparts of the medieval town collapsed, crushing several parked cars including a vehicle belonging to the Service for the Protection of Historic Monuments of Montenegro.